

User manual

Controller

SIGMA CONTROL SMART

901710 11 E

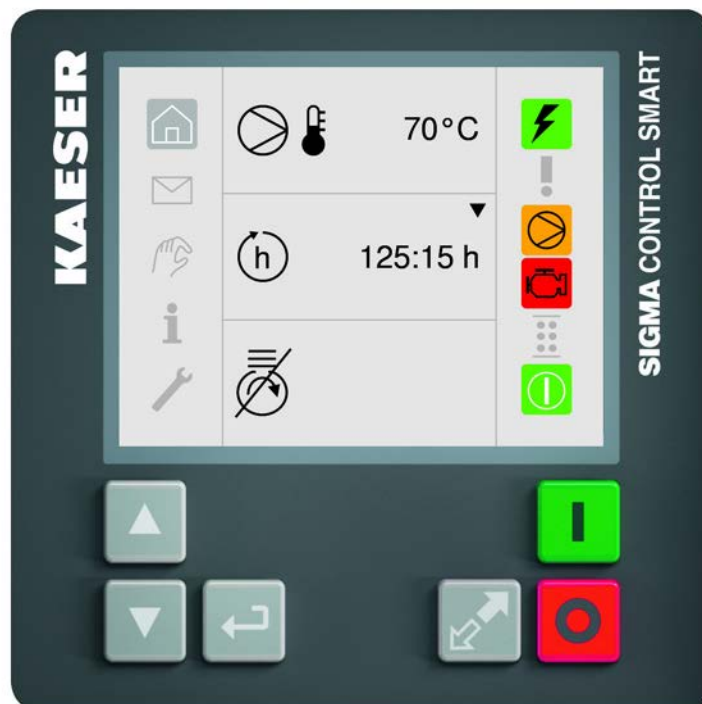

Manufacturer:

KAESER KOMPRESSOREN SE

96410 Coburg • PO BOX 2143 • GERMANY • Tel. +49-(0)9561-6400 • Fax +49-(0)9561-640130

www.kaeser.com

Contents

1 Quick reference guide	
1.1 Operating elements	5
1.2 Display elements	6
1.3 Menu structure	8
1.4 Functions overview	9
2 About this document	
2.1 Warning notices	10
2.2 Material damage warnings	10
2.3 Symbols and pictograms	11
2.4 Copyright	11
3 Safety and responsibility	
3.1 Basic information	12
3.2 Intended use	12
4 Design and function	
4.1 Controller overview	13
4.2 Operating elements	13
4.3 Display elements	14
4.4 Display	16
4.5 Menu structure	16
4.5.1 Main menu	18
4.5.2 Error memory	20
4.5.3 Settings menu	21
4.5.4 System information	25
4.5.5 Maintenance indicator	27
4.6 Operating sequence	28
4.7 Indicator for diesel particulate filter regeneration level	30
4.8 ob Automatic start/stop	31
5 Commissioning	
5.1 Switching the controller voltage on or off	32
5.2 Controller settings	33
5.2.1 Changing settings	33
5.2.2 Entering the password	34
5.2.3 Setting the compressed air discharge pressure	34
5.2.4 Setting the measurement units	36
5.2.5 Setting the display brightness	37
5.2.6 Setting automatic regeneration for the diesel particulate filter	38
5.2.7 Switching the engine control unit to continuous operation	38
5.2.8 Operating the external filling device with separate fuel pump	39
5.2.9 Activating the radio remote control	39
6 Operation	
6.1 Testing the safety functions	41
6.1.1 Activating the test mode	41
6.1.2 Testing the safety valve	42
6.1.3 Testing the airdend discharge temperature safety shutdown	43
6.2 Adjusting the fan	44
6.3 Operation with Automatic start/stop	45
6.3.1 Activating Automatic start/stop	45
6.3.2 Setting Automatic start/stop	45
6.3.3 Ending Automatic start/stop mode	46
6.4 Reference run for error acknowledgement	47

7	Fault recognition and rectification	
7.1	Fault message on the controller	48
7.1.1	Confirming and acknowledging a fault message	48
7.1.2	Fault message overview	49
7.2	Warning message on the controller	52
7.2.1	Confirming and acknowledging a warning message	52
7.2.2	Warning message overview	53
7.2.3	Initiating parked regeneration	54
7.3	Maintenance message on the controller	56
7.3.1	Resetting the maintenance timer	56
7.3.2	Maintenance message overview	57
8	Annexe	
8.1	Starting / shutting down the operating sequence	59
8.2	Starting / shutting down the operating sequence (Automatic start/stop)	60
8.3	Menu display	61
	Index	62

1 Quick reference guide

1.1 Operating elements

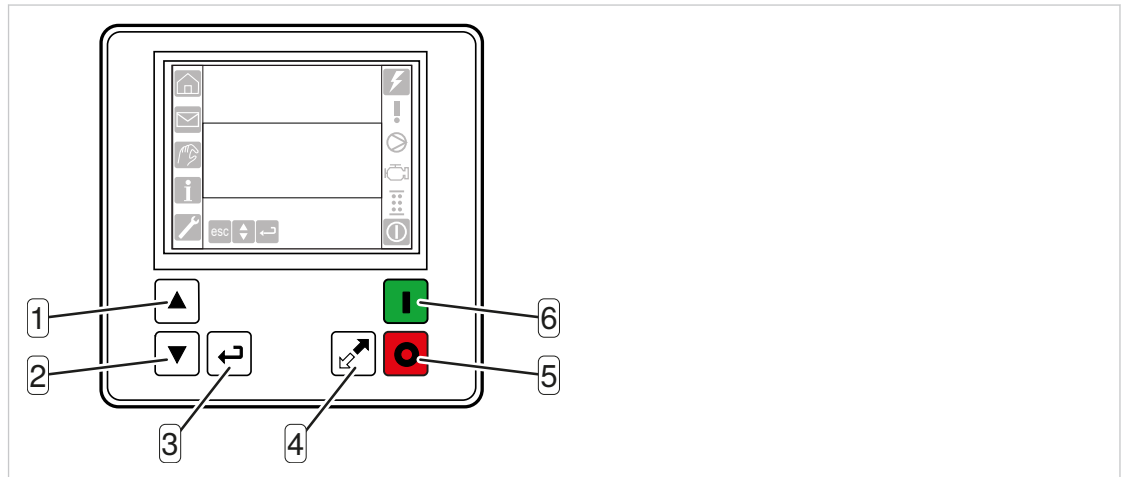

Fig. 1 Operating elements

Item	Operating element	Symbol	Function
①	«Up»		<ul style="list-style-type: none"> ▪ Scrolls the menu up ▪ Increases a parameter value
②	«Down»		<ul style="list-style-type: none"> ▪ Scrolls the menu down ▪ Reduces a parameter value
③	«Enter»		<ul style="list-style-type: none"> ▪ Opens the selected submenu ▪ Exits Edit mode and saves
④	«LOAD/IDLE»		Switches between the «LOAD/IDLE» operating points
⑤	«OFF»		Switches the machine off
⑥	«ON»		Switches the machine on

Tab. 1 Operating elements

1.2 Display elements

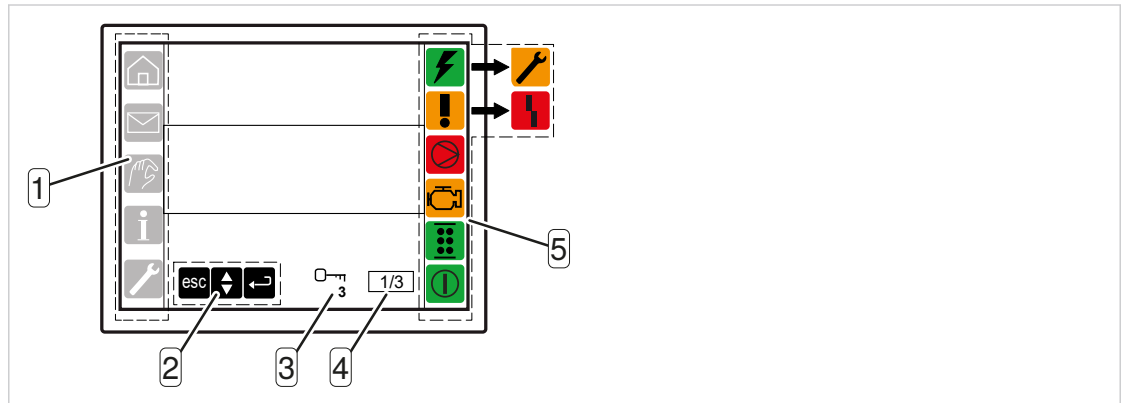





















Fig. 2 Display elements



Item	Display element	Symbol	Function
①	Menu bar		Main menu Displays current operating data
			Error memory Displays current faults and warnings
			Settings menu Displays the current parameters
			System information Displays data relating to the machine and software
			Maintenance Displays time remaining until next maintenance due
②	Navigation menu		Escape <ul style="list-style-type: none"> ▪ Navigates to the next menu level up ▪ Operation with the «Enter» key enabled
			Up/Down Navigation by means of the «Up» and «Down» keys enabled
			Enter Operation with the «Enter» key enabled
③	Password level		Displays the current password level (password level 1 shown)
④	Current page		Displays the current page

Item	Display element	Symbol	Function
5	Status bar		Controller voltage <ul style="list-style-type: none"> ▪ Illuminates in green when the controller voltage is switched on ▪ Is extinguished when maintenance is pending
			Maintenance <ul style="list-style-type: none"> ▪ Illuminates in orange when maintenance is pending ▪ In this case, replaces the Controller voltage symbol
			Warning <ul style="list-style-type: none"> ▪ Illuminates in orange when a warning is pending ▪ Is extinguished when a fault is pending ▪ The machine is not shut down
			Fault <ul style="list-style-type: none"> ▪ Illuminates in red when a fault is pending ▪ In this case, replaces the Warning symbol ▪ The machine is shut down
			Compressor <ul style="list-style-type: none"> ▪ Illuminates in orange when a compressor warning is pending ▪ Illuminates in red when a compressor fault has occurred
			Combustion engine <ul style="list-style-type: none"> ▪ Illuminates in orange when a combustion engine warning is pending ▪ Illuminates in red when a combustion engine fault has occurred
			Diesel particulate filter <ul style="list-style-type: none"> ▪ Illuminates in green during "normal operation" ▪ Illuminates in green and orange with "Active regeneration request" ▪ Illuminates in orange when a warning is pending ▪ Illuminates in orange and red when "Parked regeneration" requested ▪ Illuminates in red when a fault has occurred
			Ready to start <ul style="list-style-type: none"> ▪ Flashes green when ready to start ▪ Illuminates in green when combustion engine running ▪ Is extinguished in the event of a fault ▪ Inactive when restart inhibitor activated

Tab. 2 Display elements





Status display in menu bar

Symbol	Symbol display	Menu bar
	Black	Active

Symbol	Symbol display	Menu bar
	Grey	Passive
	Black background	Active and selected symbol
	Grey background	Selected symbol and activated menu

Tab. 3 Example: Status display of system information symbol on machine

1.3 Menu structure

Symbol	Menu level 1	Menu level 2
	Main menu	<ul style="list-style-type: none"> ▪ Machine operating data ▪ Combustion engine operating data ▪ Compressor operating data ▪ Diesel particulate filter operating data
	Error memory	<ul style="list-style-type: none"> ▪ Fault messages ▪ Warning messages
	Settings menu	<ul style="list-style-type: none"> ▪ Setpoint pressure setting ▪ Setpoint pressure enabling ▪ Temperature unit setting ▪ Pressure unit setting ▪ Display brightness setting ▪ Engine control unit setting ▪ Activate/deactivate TÜV inspection ▪ Diesel particulate filter setting ▪ Activate/deactivate Automatic start/stop ▪ External filling device setting ▪ Viscous fan setting ▪ Maintenance interval setting
	System information	<ul style="list-style-type: none"> ▪ Machine ▪ Controller software
	Maintenance indicator	<ul style="list-style-type: none"> ▪ Compressor ▪ Combustion engine

Tab. 4 Menu structure



A detailed description of the individual menus can be found in chapter [4.5 Menu structure](#)

1.4 Functions overview

Function	Menu
5.2.4.1 Setting the pressure units	Settings menu
5.2.4.2 Setting the temperature units	Settings menu
5.2.3.1 Enabling compressed air adjustment	Settings menu
5.2.3.2 Setting the pressure	Settings menu
5.2.5 Setting the display brightness	Settings menu
5.2.6 Setting automatic regeneration for the diesel particulate filter	Settings menu
5.2.7 Switching the engine control unit to continuous operation	Settings menu
5.2.8 Operating the external filling device with separate fuel pump	Settings menu
5.2.9 Activating the radio remote control	Settings menu
6.1 Testing the safety functions	Settings menu
6.3.2 Setting Automatic start/stop	Settings menu
7.1.1 Confirming and acknowledging a fault message	Error memory
7.2.1 Confirming and acknowledging a warning message	Error memory
7.2.3 Initiating parked regeneration	Main menu
7.3.1 Resetting the maintenance timer	Maintenance indicator

Tab. 5 Functions overview

2 About this document



Read the operating manual carefully and ensure you are familiar with the contents before using this product.

This document constitutes an integral part of the product and describes the product at the time of initial delivery following completion. Keep the document throughout the entire lifetime of the product and pass it on to any subsequent owner or user.

For reasons of improved readability, the simultaneous use of the male, female and plural language forms has been dispensed with. All personal designations apply equally to all genders.

Supplement the manual with any amendments that may be provided by KAESER. Provide the data from the nameplate wherever you are asked to do so. This simplifies orientation for every user.

The illustrations in this manual are basic representations, which may differ from the actual in minor details.

Where any menu displays are depicted in this document, these serve as examples only. Menus or functions may be depicted in the document that are not available in the specific product, or will only be introduced at a later point in time.

2.1 Warning notices

Warning notices warn of hazards that can lead to personal injury and provide instructions on how to avoid damage. Warning notices precede actions associated with hazards and also apply to sub-chapters if they precede the chapter.

Warning notices indicate three levels of hazard identified by the corresponding signal word:

Signal word	Consequence if the hazard is not avoided
DANGER	Hazard with a high level of risk that will result in death or serious injury if not avoided
WARNING	Hazard with a medium level of risk that may lead to death or serious injury if not avoided
CAUTION	Hazard with a low level of risk that may lead to minor or moderate injury if not avoided

Tab. 6 Signal words and their consequences

Example:



WARNING

Description of the hazard, cause and consequences

- ▶ Instructions on how to avoid the hazard

2.2 Material damage warnings

Material damage warnings warn of situations that can lead to material/property damage and provide instructions on how to avoid damage. Material damage warnings precede actions associated with risks and also apply to sub-chapters if they precede the chapter.

Material damage warnings are identified by their signal word NOTICE.















Example:

NOTICE
Description of the hazard, cause and consequences

- ▶ Instructions on how to avoid the damage

2.3 Symbols and pictograms

Symbols and pictograms in this document draw your attention to information that requires special attention. Follow all instructions provided to prevent damage.

Representation	Meaning	Representation	Meaning
	Section or information relating to an optional equipment feature		Software-dependent button on display for triggering an operating function
	This symbol indicates an individual action requirement	1. ... 2. ... 3. ...	A series of action requirements are numbered consecutively. Follow the sequence accordingly.
«Operating element»	Visualisation of an operating element, e.g. a key	<i>Display element</i>	Visualisation of a display element, e.g. a control indicator
	Safety-related condition that must be fulfilled in order to be able to perform the subsequent activity		Prerequisite that must be met in order to be able to perform the subsequent activity
	Useful information or information that needs to be observed		Reference to another source of information
	Materials and tools		Spare parts
	Tool		Information or action relating to environmental protection
	Assistance relating to an activity		Assistance relating to an individual action step
	Result of an implemented activity		Result of an individual action step

Tab. 7 Symbols and pictograms

2.4 Copyright

This manual is copyright protected. Should you have any queries relating to usage and duplication of this documentation, please contact KAESER. KAESER will be glad to provide advice regarding the appropriate use of the information.

3 Safety and responsibility

3.1 Basic information

The SIGMA CONTROL SMART controller is manufactured to the latest engineering standards and recognised safety regulations.

Safety regulations relating to the machine in which it is installed also apply to the controller.

3.2 Intended use

SIGMA CONTROL SMART The SIGMA CONTROL SMART controller is designed exclusively for controlling the machine in which it has been installed at the factory. Any other use shall be considered improper. The manufacturer shall not be liable for any damage that may result from improper use. The operator shall be solely liable for any risks incurred.

Adhere to the instructions provided in this operating manual, as well as the operating manual for the machine in which the controller is installed.

4 Design and function

4.1 Controller overview

SIGMA CONTROL SMART Controls, regulates, monitors and protects your machine.

The SIGMA CONTROL SMART is used to display and set all of the parameters required for machine operation. Parameters are protected by user-dependent access levels.

The control and regulating function enables optimal duty cycles for the combustion engine with lowest possible energy consumption, adapted to the actual compressed air demand of the connected consumers.

The monitoring function enables:

- Monitoring of maintenance-relevant components in the combustion engine and compressor via interval counters.
- Display of warning messages or maintenance messages, as an indication of upcoming maintenance tasks.

The protection function enables automatic shutdown in the event of a fault, such as excessive temperature or overpressure, that could result in damage to the machine.

4.2 Operating elements

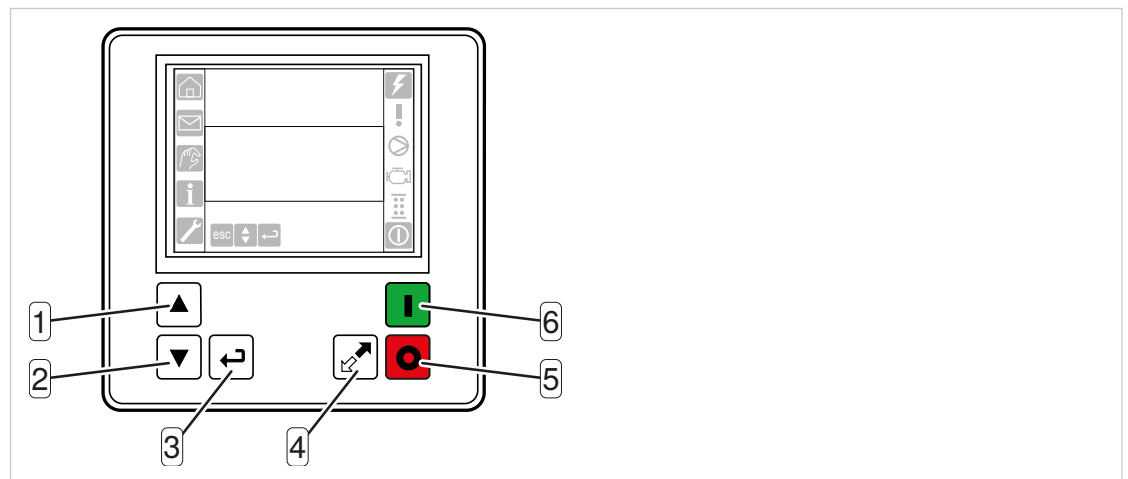

Fig. 3 Operating elements

Item	Operating element	Symbol	Function
①	«Up»		<ul style="list-style-type: none"> ▪ Scrolls the menu up ▪ Increases a parameter value
②	«Down»		<ul style="list-style-type: none"> ▪ Scrolls the menu down ▪ Reduces a parameter value
③	«Enter»		<ul style="list-style-type: none"> ▪ Opens the selected submenu ▪ Exits Edit mode and saves
④	«LOAD/IDLE»		Switches between the «LOAD/IDLE» operating points
⑤	«OFF»		Switches the machine off

Item	Operating element	Symbol	Function
⑥	«ON»		Switches the machine on

Tab. 8 Operating elements

4.3 Display elements

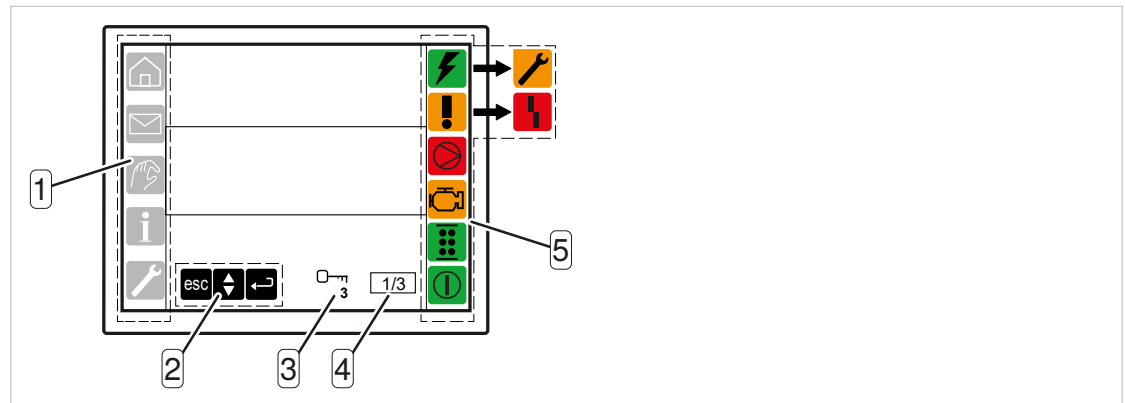















Fig. 4 Display elements

Item	Display element	Symbol	Function
①	Menu bar		Main menu Displays current operating data
			Error memory Displays current faults and warnings
			Settings menu Displays the current parameters
			System information Displays data relating to the machine and software
			Maintenance Displays time remaining until next maintenance due
②	Navigation menu		Escape <ul style="list-style-type: none"> ▪ Navigates to the next menu level up ▪ Operation with the «Enter» key enabled
			Up/Down Navigation by means of the «Up» and «Down» keys enabled
			Enter Operation with the «Enter» key enabled
③	Password level		Displays the current password level (password level 1 shown)

Item	Display element	Symbol	Function
④	Current page		Displays the current page
⑤	Status bar		Controller voltage <ul style="list-style-type: none"> ▪ Illuminates in green when the controller voltage is switched on ▪ Is extinguished when maintenance is pending
			Maintenance <ul style="list-style-type: none"> ▪ Illuminates in orange when maintenance is pending ▪ In this case, replaces the Controller voltage symbol
			Warning <ul style="list-style-type: none"> ▪ Illuminates in orange when a warning is pending ▪ Is extinguished when a fault is pending ▪ The machine is not shut down
			Fault <ul style="list-style-type: none"> ▪ Illuminates in red when a fault is pending ▪ In this case, replaces the Warning symbol ▪ The machine is shut down
			Compressor <ul style="list-style-type: none"> ▪ Illuminates in orange when a compressor warning is pending ▪ Illuminates in red when a compressor fault has occurred
			Combustion engine <ul style="list-style-type: none"> ▪ Illuminates in orange when a combustion engine warning is pending ▪ Illuminates in red when a combustion engine fault has occurred
			Diesel particulate filter <ul style="list-style-type: none"> ▪ Illuminates in green during “normal operation” ▪ Illuminates in green and orange with “Active regeneration request” ▪ Illuminates in orange when a warning is pending ▪ Illuminates in orange and red when “Parked regeneration” requested ▪ Illuminates in red when a fault has occurred
			Ready to start <ul style="list-style-type: none"> ▪ Flashes green when ready to start ▪ Illuminates in green when combustion engine running ▪ Is extinguished in the event of a fault ▪ Inactive when restart inhibitor activated

Tab. 9 Display elements

Status display in menu bar

Symbol	Symbol display	Menu bar
	Black	Active
	Grey	Passive
	Black background	Active and selected symbol
	Grey background	Selected symbol and activated menu

Tab. 10 Example: Status display of system information symbol on machine





4.4 Display

The display allows the user to read off information and check entered data. The display is fully graphical.

Pressing the «Enter» key opens up the main menu. From there you can access the different submenus.

During operation, the operating display is shown.

4.5 Menu structure

Symbol	Menu level 1	Menu level 2
	Main menu	<ul style="list-style-type: none"> ▪ Machine operating data ▪ Combustion engine operating data ▪ Compressor operating data ▪ Diesel particulate filter operating data
	Error memory	<ul style="list-style-type: none"> ▪ Fault messages ▪ Warning messages
	Settings menu	<ul style="list-style-type: none"> ▪ Setpoint pressure setting ▪ Setpoint pressure enabling ▪ Temperature unit setting ▪ Pressure unit setting ▪ Display brightness setting ▪ Engine control unit setting ▪ Activate/deactivate Test safety functions ▪ Diesel particulate filter setting ▪ Activate/deactivate Automatic start/stop ▪ External filling device setting ▪ Viscous fan setting ▪ Maintenance interval setting
	System information	<ul style="list-style-type: none"> ▪ Machine ▪ Controller software

Symbol	Menu level 1	Menu level 2
	Maintenance indicator	<ul style="list-style-type: none">▪ Compressor▪ Combustion engine

Tab. 11 Menu structure

4.5.1 Main menu

The main menu displays the current operating data.

Select the  symbol in the menu bar to open the main menu.

Operating indicators on display

The screen displays graphical symbols and alphanumerical characters, the meaning of which is derived from the context of the indicators.

The two upper lines on the display indicate current operating data.

The two bottom lines on the display indicate the current operating state.

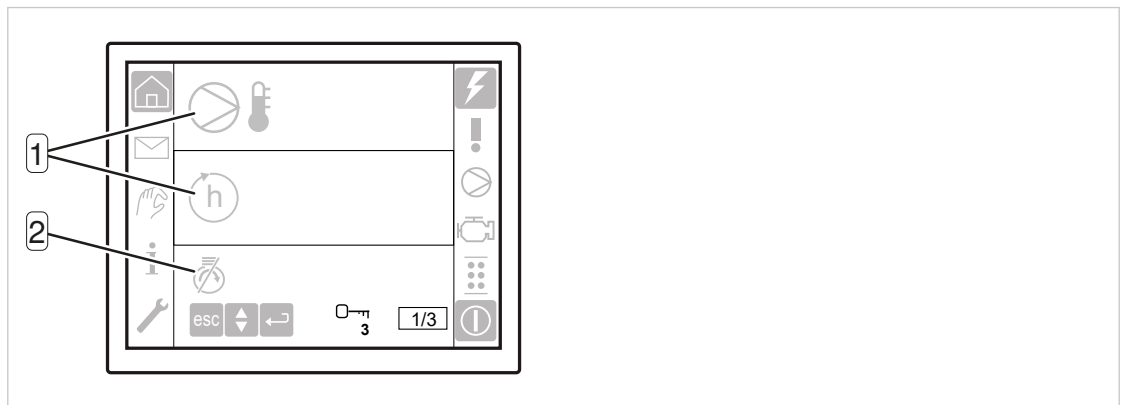

















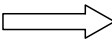



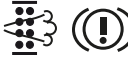

Fig. 5 Operating data and states

- 1 Operating data
- 2 Operating states

Symbol	Meaning
	Airend discharge temperature
	Operating hours
	Fuel tank fill level: <ul style="list-style-type: none"> ▪ Yellow bar = Fuel level ▪ Orange bar = Reserve zone ▪ Red flashing bar = Fuel tank empty
	Pressure in oil separator tank
	Specified setpoint pressure
	Network pressure sensor value
	Battery voltage
	Engine speed
	Coolant temperature

Symbol	Meaning
 IN	Diesel particulate filter temperature at inlet
 OUT	Diesel particulate filter temperature at outlet
 SOOT	Diesel particulate filter soot load

Tab. 12 Operating data indicator

Symbol	Meaning	Description
	Combustion engine READY	Combustion engine is off
	Preheating	Combustion engine is being preheated
	Warm-up phase	Combustion engine starts and machine warms up
	IDLE operating point	Machine running in IDLE operating point
	Start-up	<ul style="list-style-type: none"> Combustion engine running up The load requirement is saved.
	LOAD operating point	<ul style="list-style-type: none"> Machine running in LOAD operating point Full speed and flow rate only after combustion engine has warmed up
	Run-on phase	Cool-down phase, cooling period is indicated dependent upon operating temperature
	Back pressure	<ul style="list-style-type: none"> The prevailing pressure in the oil separator tank is displayed; the machine cannot be started. Display is in bar or psi, as per menu setting
	Parked regeneration	Diesel particulate filter regeneration (specified by controller).
	Automatic start/stop	Automatic start/stop option active. Machine controller runs in <i>automatic mode</i> .

Tab. 13 Operating state indicator

4.5.2 Error memory

Any fault and warnings occurring are listed in the error memory menu.

Select the  symbol in the menu bar to open the error memory menu.

Active faults or warnings are surrounded by a coloured frame:

- Warnings: Orange
- Faults: Red

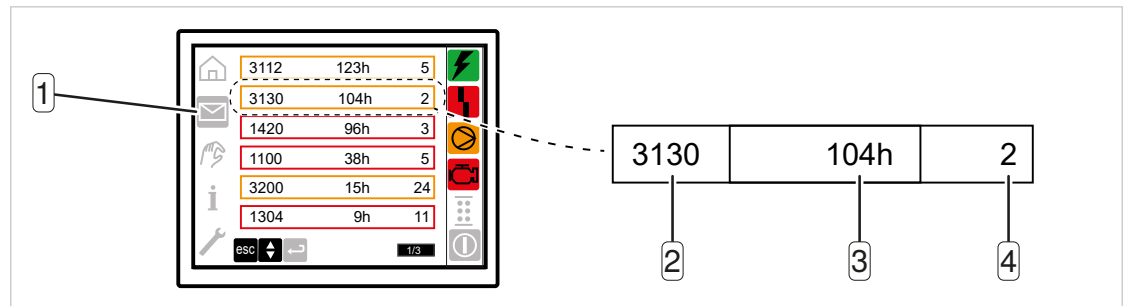

Fig. 6 Error memory

- ① Error memory symbol
- ② Code indicator
- ③ Operating hour indicator for last occurrence
- ④ Frequency

Code:

The key for the four-digit code ② indicated on the display is as follows.

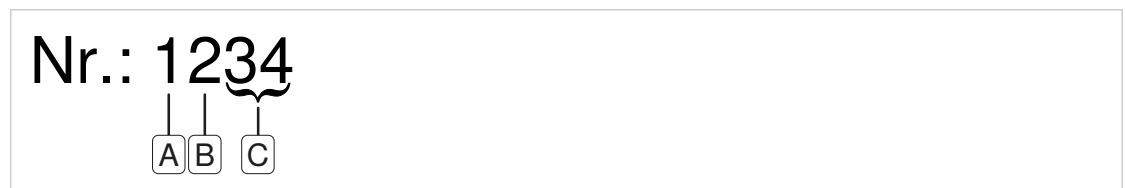

Fig. 7 Code structure

Further criteria for reading the code

Item	Position	Description
a)	Position 1	Message type: <ul style="list-style-type: none"> ▪ 1 – Error ▪ 2 – Maintenance ▪ 3 – Warning
b)	Position 2	Location of occurrence: <ul style="list-style-type: none"> ▪ 1 – Combustion engine ▪ 2 – Compressor ▪ 3 – Controller ▪ 4 – General
c)	Positions 3 and 4	Code number from 00 to 99

Tab. 14 Code explanation

4.5.3 Settings menu

The parameters for the controller are set in the Settings menu.

Select the  symbol in the menu bar to open the Settings menu.
The Settings menu is displayed across multiple screen pages.



Password protection:

- Access to some of the settings is password-protected.
- Entries and modifications in the Settings menu can only be carried out by entering a password.

Settings menu, page 1:

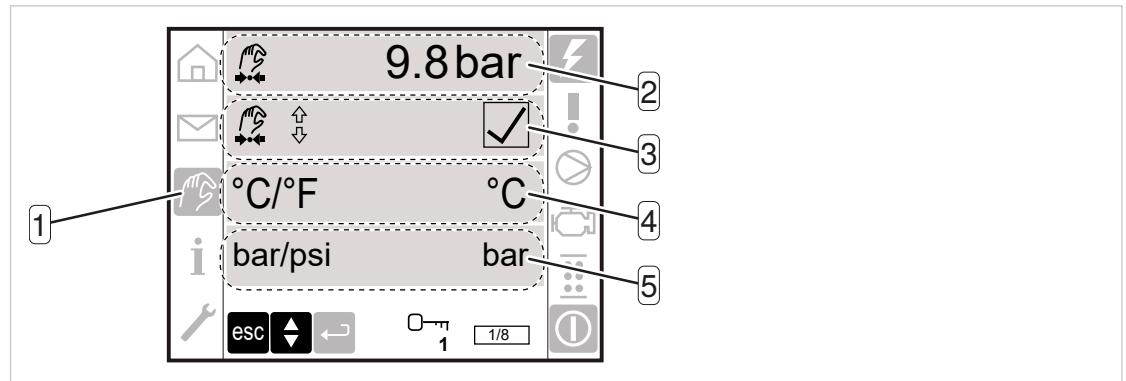

Fig. 8 Settings menu display, page 1

- | | |
|---|------------------------------------|
| ① Settings menu symbol | ④ Temperature display unit setting |
| ② Compressed air discharge pressure setting (setpoint pressure) | ⑤ Pressure display unit setting |
| ③ Setpoint pressure adjustment enabled | |

Settings menu, page 2:

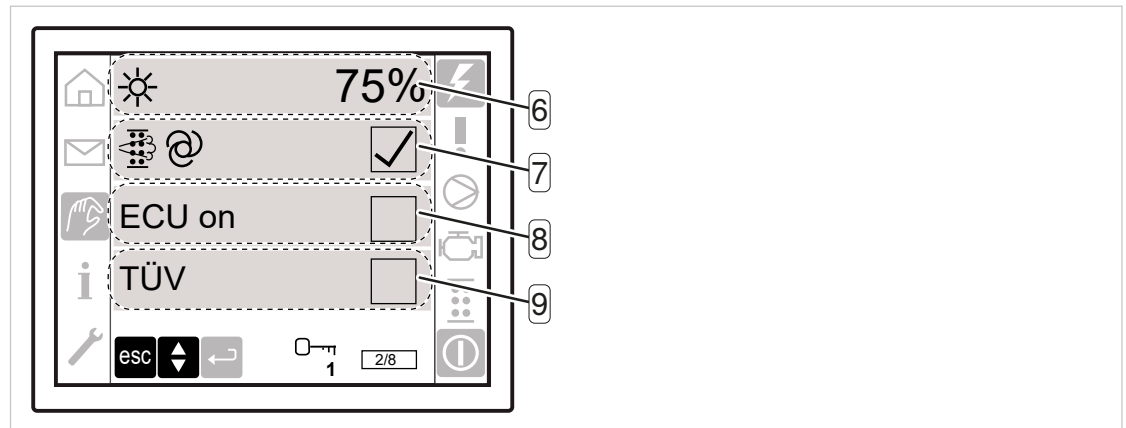

Fig. 9 Settings menu display, page 2

- | | |
|--|---------------------------------------|
| ⑥ Display brightness setting | ⑧ Activate engine control unit |
| ⑦ Diesel particulate filter regeneration activated for current operating cycle | ⑨ Activate safety functions test mode |

Settings menu, page 3

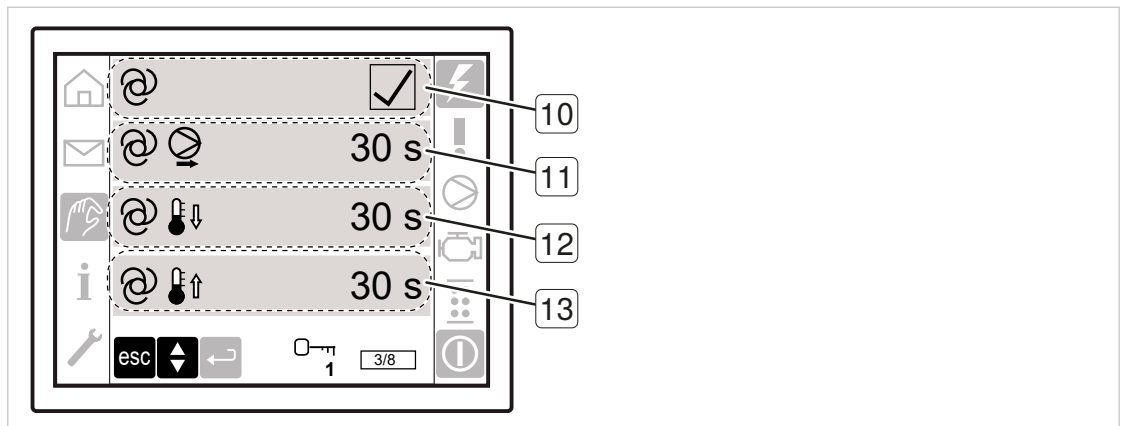

Fig. 10 Settings menu display, page 3

- 10 Activate Automatic start/stop
 - 11 Run-on period setting for Automatic start/stop
- 12 Cooling-down period setting for Automatic start/stop
 - 13 Warm-up period setting for Automatic start/stop

Settings menu, page 4:

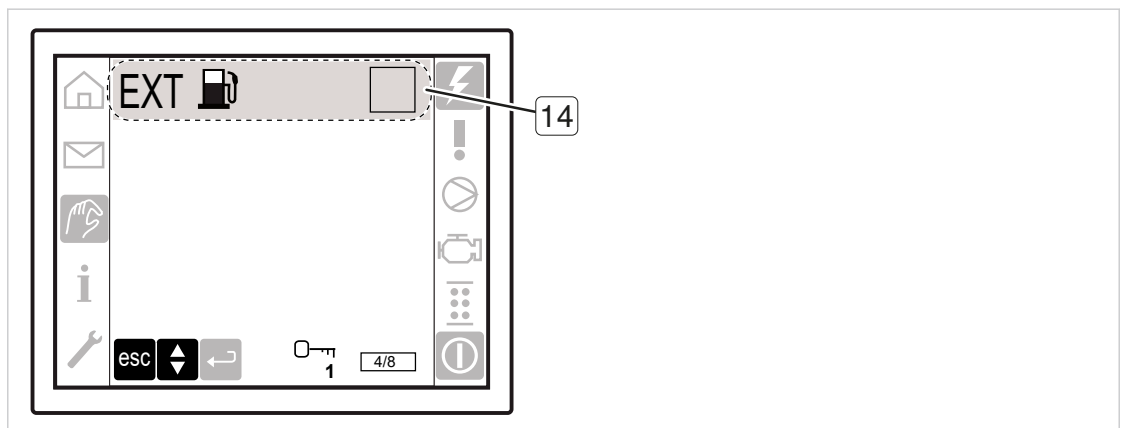

Fig. 11 Settings menu display, page 4

- 14 Activate external filling device

Settings menu, page 5:

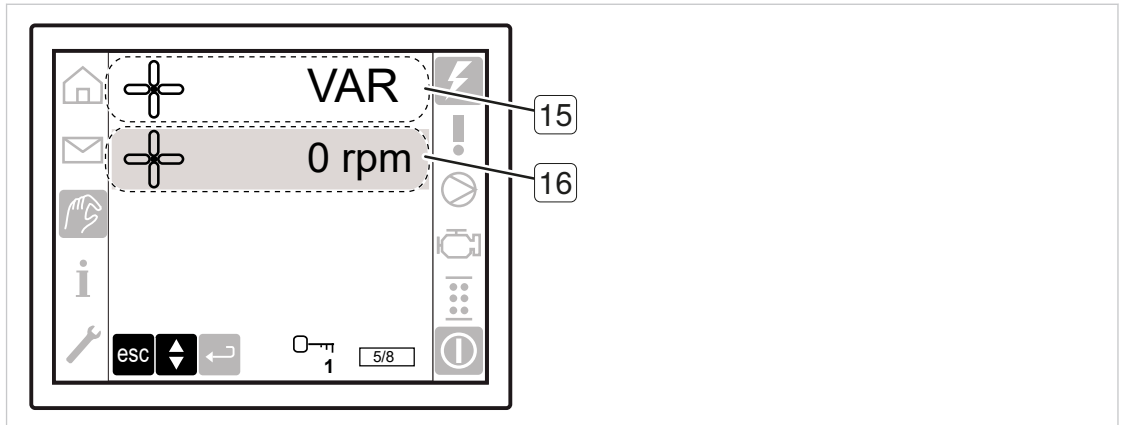

Fig. 12 Settings menu display, page 5

- 15 Activate viscous fan
- 16 Viscous fan speed

Settings menu, page 6:

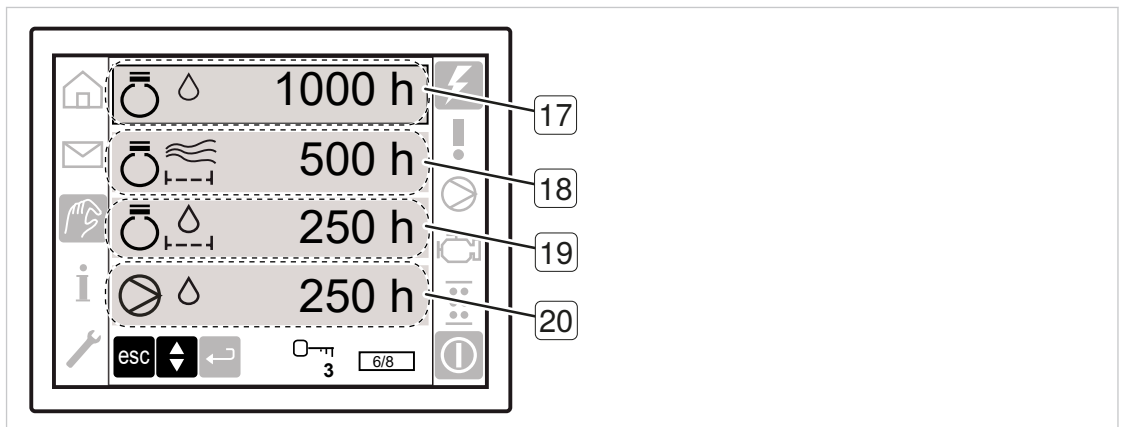

Fig. 13 Settings menu display, page 6

- 17 Engine oil maintenance interval setting
- 18 Combustion engine air filter maintenance interval setting
- 19 Combustion engine oil filter maintenance interval setting
- 20 Compressor cooling oil maintenance interval setting

Settings menu, page 7:

Fig. 14 Settings menu display, page 7

- 21 Compressor air filter maintenance interval setting
- 22 Compressor oil filter maintenance interval setting

Settings menu, page 8:

Fig. 15 Settings menu display, page 8

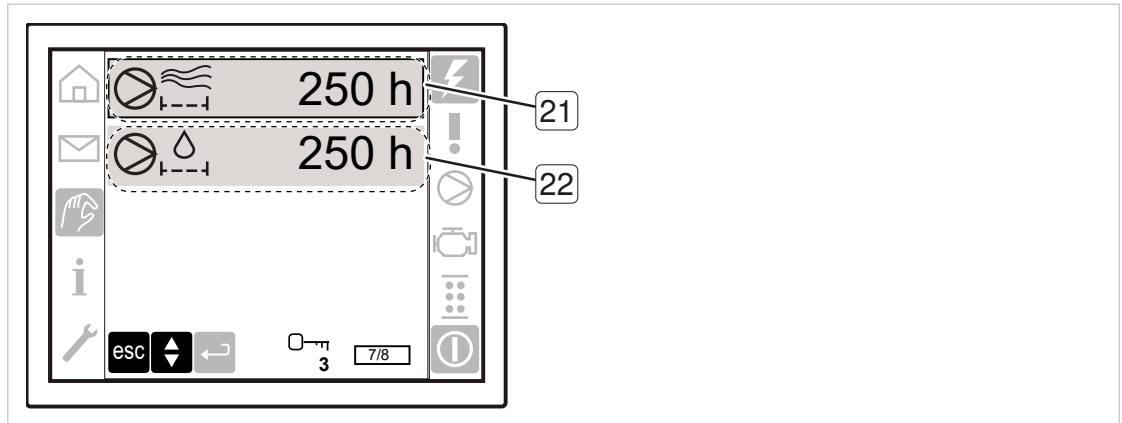
- 23 Activate radio remote control setting

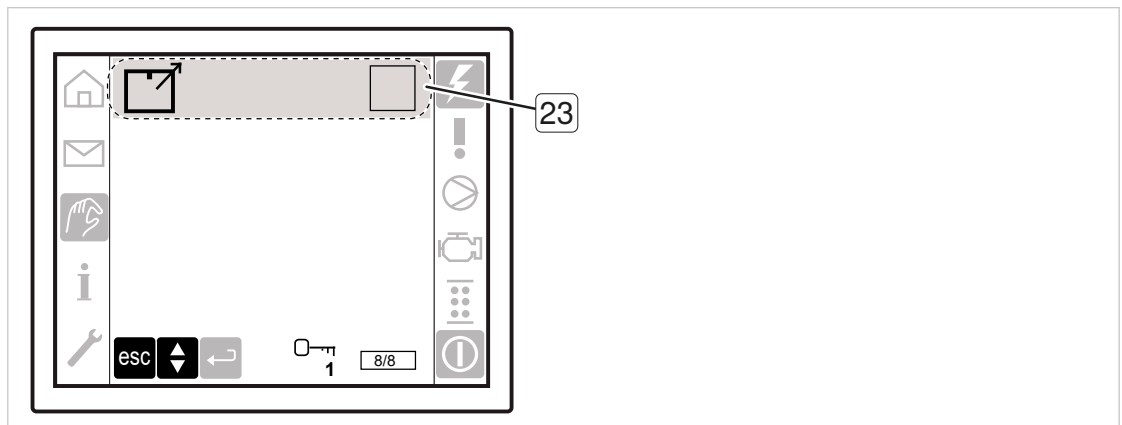

A detailed description for the setting of individual parameters can be found in chapter [5.2 Controller settings](#)

4.5.4 System information

The System Information menu displays data relating to the machine and software.

Select the **i** symbol in the menu bar to open the System Information menu.

On the second page you can find the following system information:

System information menu, page 1:

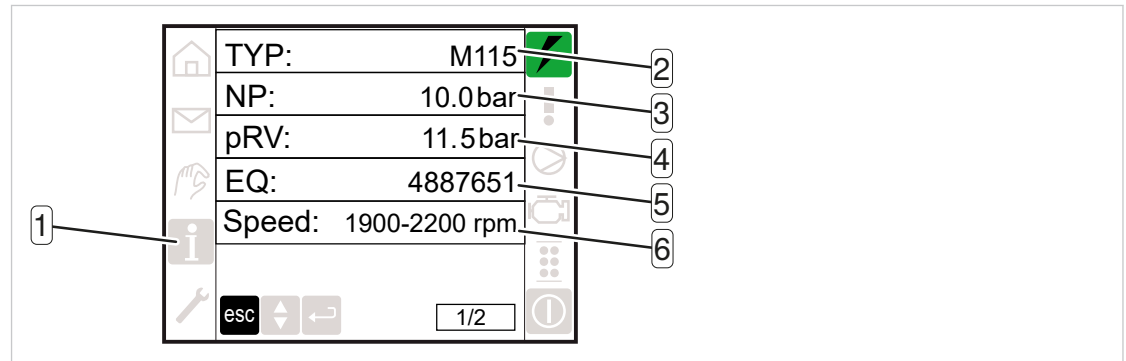

Fig. 16 System information menu, page 1

- | | |
|-----------------------------|---|
| 1 System information symbol | 4 Installed safety valve |
| 2 Machine type | 5 Machine equipment number |
| 3 Rated pressure | 6 Engine/motor speed at IDLE operating point – LOAD operating point |

System information menu, page 2:

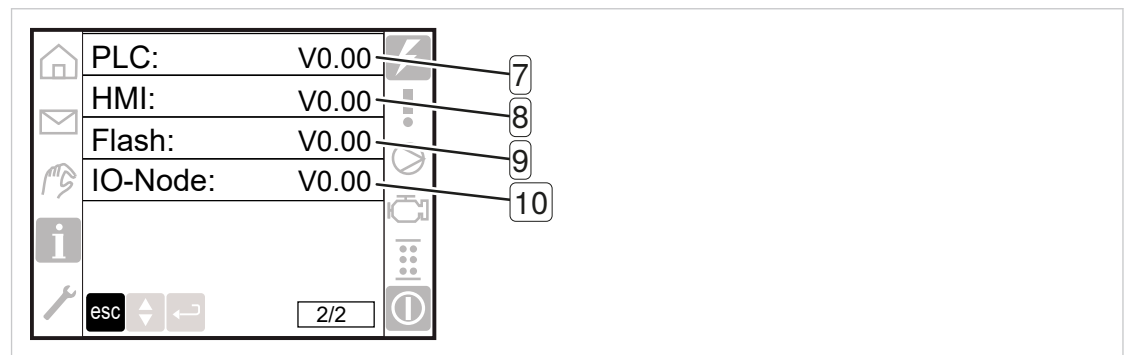

Fig. 17 System information menu, page 2

- | | |
|---|--|
| 7 Software version for controller (PLC) | 9 Software version for flash data (controller) |
| 8 Software version for controller display (HMI) | 10 Software version for IO module |

Combustion engine error memory:

In the System Information menu, pending engine faults can be displayed.



Pressing the «Down» key for 3 seconds opens the active error memory for the combustion engine. To return to the System Information menu, press and hold the «Up» key for 3s.

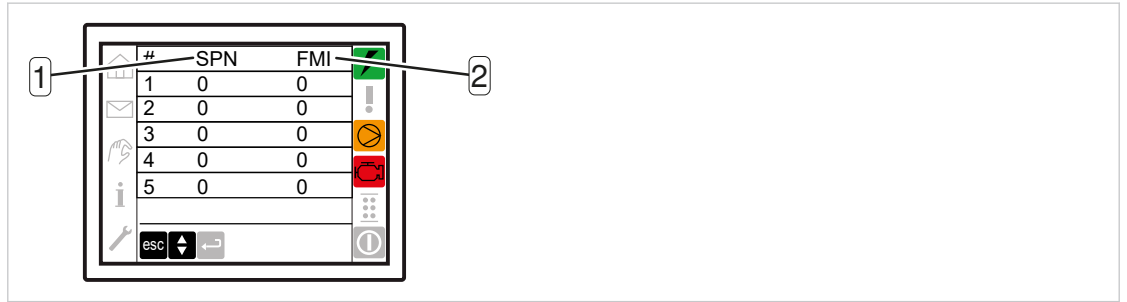



Fig. 18 Combustion engine active error memory indicator

Item	Indicator	Meaning	Description
①	SPN	Suspect parameter number	Error ID
②	FMI	Failure mode identifier	Error type

Tab. 15 Combustion engine active error memory

4.5.5 Maintenance indicator

Select the  symbol in the menu bar to open the maintenance indicator menu.

Maintenance indicator menu overview, page 1:

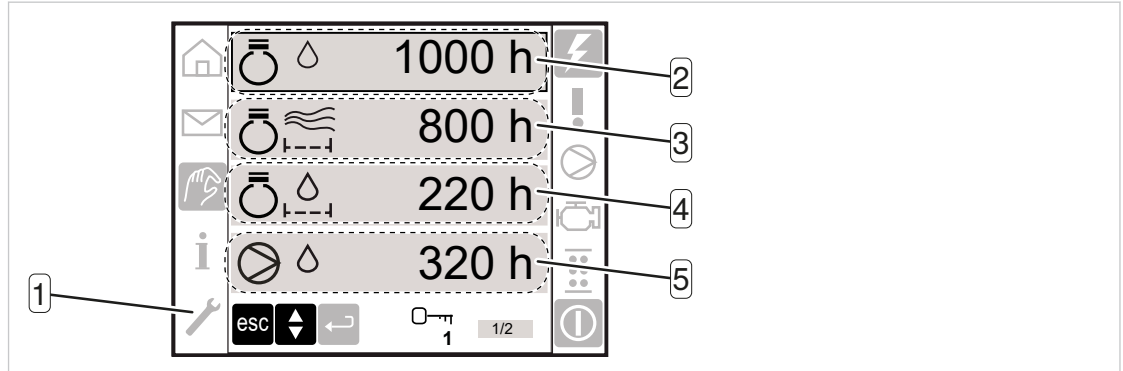

Fig. 19 Maintenance indicator display, page 1

- | | |
|---|---|
| ① Maintenance menu symbol | ④ Combustion engine oil filter maintenance timer, counts down |
| ② Engine/motor oil maintenance timer, counts down | ⑤ Compressor cooling oil maintenance timer, counts down |
| ③ Combustion engine air filter maintenance timer, counts down | |

Maintenance indicator menu overview, page 2:

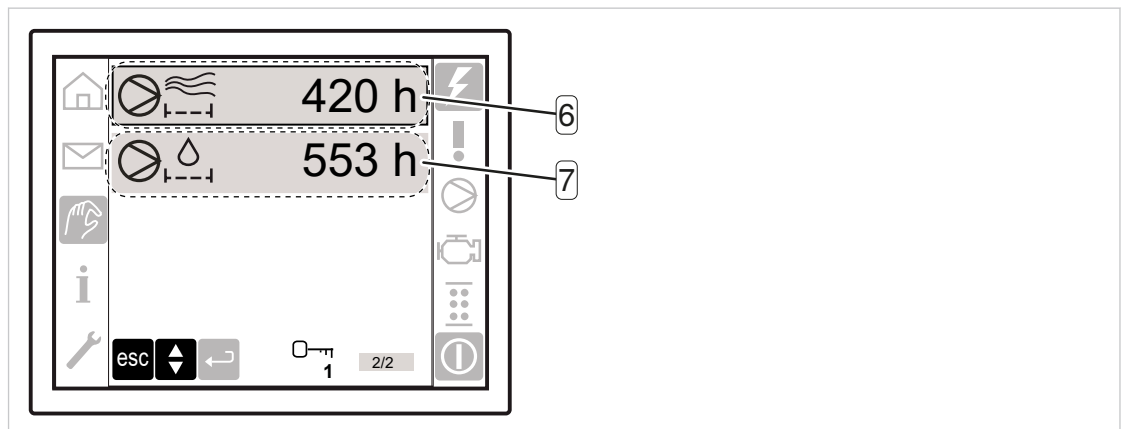

























Fig. 20 Maintenance indicator display, page 2

- | |
|--|
| ① Compressor air filter maintenance timer, counts down |
| ② Maintenance timer reset for compressor oil filter, counts down |

4.6 Operating sequence

Operating sequence	Key	Indicator	Description
Ready to start	—		READY flashes green
START: ▶ Activate «START».			<ul style="list-style-type: none"> At low ambient temperatures, preheating is activated automatically Preheating time is dependent on the ambient temperature The combustion engine is started automatically Maximum starting time 15 s Once the starting speed has been reached, the starter disengages
Warm-up phase:		 	The machine runs in the IDLE operating point until: The setpoint airdisch discharge temperature is reached. or The specified warm-up period has elapsed when operating in Automatic start/stop.
IDLE operating point			The machine is ready for changeover to the IDLE operating point
LOAD operating point ▶ Activate the «LOAD/IDLE» key.			The machine is switched to the LOAD operating point.
Start-up: ▶ Activate the «LOAD/IDLE» key.		 	Combustion engines with electronic control: When the engine speed reaches the setpoint speed for LOAD, it switches over to the LOAD operating point.
Setting the compressed air discharge pressure: ▶ Press the «Up» or «Down» key for ≥ 2 s. ▶ Use the «Up» or «Down» key to set the desired pressure. ▶ Confirm with the «ENTER» key.	    	 8,5 bar	The pressure adjustment option must be activated! The discharge pressure is set. The set value for the compressed air discharge pressure is active immediately and remains saved.

Operating sequence	Key	Indicator	Description
<i>Either</i> Run-on phase: ▶ Activate the «LOAD/IDLE» key.			The machine switches to <i>Unloaded run-on</i> . <ul style="list-style-type: none"> ▪ The combustion engine runs at idle speed ▪ The machine is vented ▪ The machine is ready for changeover to the LOAD operating point ▪ The machine is ready for shutdown: <ul style="list-style-type: none"> ▪  0.5–3 min ▪ The combustion engine can be switched off ▶ Press the «STOP» key for ≥ 2 s.
<i>or</i> STOP: ▶ Press the «STOP» key for ≥ 1 s.		 8s	The machine switches to <i>Unloaded run-on</i> . <ul style="list-style-type: none"> ▪ The combustion engine runs at idle speed ▪ The machine is vented ▪ The cooling-down period is displayed
		 1,8 bar	Pressure in the oil separator tank > 1 bar: <i>Back pressure</i> indicator on display
			Pressure in the oil separator tank ≤ 1 bar: READY indicator on display

Tab. 16 Operating sequence SIGMA CONTROL SMART

4.8 **ob** Automatic start/stop

If the machine was purchased with the “Automatic start/stop” option, the operator can select between automatic or manual operation.

The machine is factory-set for manual operation when switched on.

Procedure in Automatic mode:

- Once the motor is ready to start, it is started automatically.
- The controller switches automatically to LOAD operation when the following parameters are fulfilled:
 - The required airend discharge temperature
 - The specified warm-up period
- Should the start-up sequence fail or be deliberately interrupted, the “restart inhibitor” is activated for a period of 20 Seconds. The remaining time is indicated on the display

5 Commissioning

5.1 Switching the controller voltage on or off

The controller voltage for the SIGMA CONTROL SMART is switched on or off by means of the «Controller ON/OFF» switch.

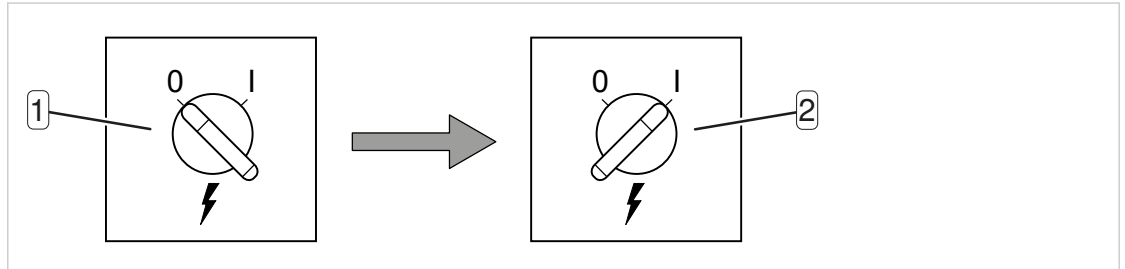

Fig. 21 «Controller ON/OFF» switch

- ① «Controller ON/OFF» switch in *OFF* position
- ② «Controller ON/OFF» switch in *ON* position

The location of the «Controller ON/OFF» switch depends on the machine type, see the operating manual for your specific machine.

5.2 Controller settings

5.2.1 Changing settings

The parameters for the controller are set in the Settings menu.

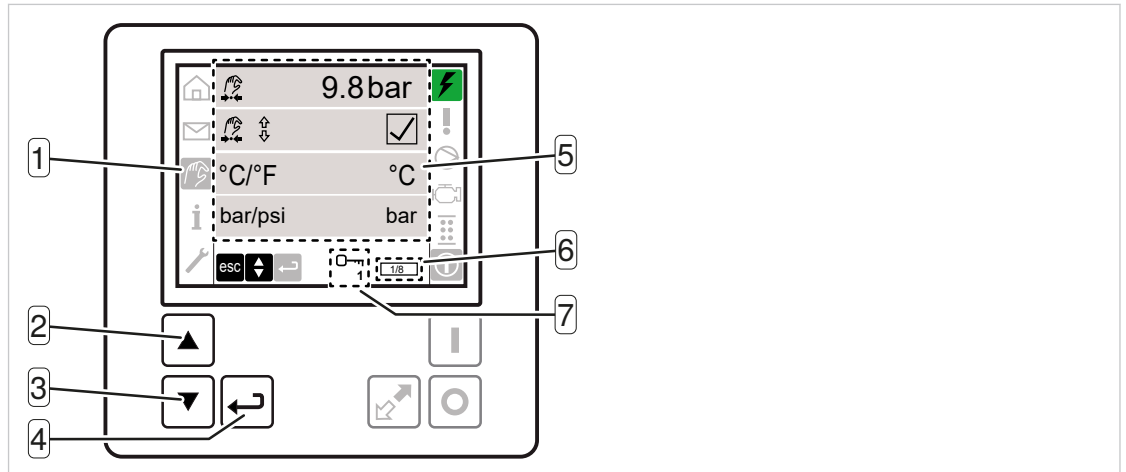

Fig. 22 Changing the operating step settings

- | | |
|-----------------|--------------------------|
| 1 Settings menu | 5 Different settings |
| 2 «Up» key | 6 Current page |
| 3 «Down» key | 7 Current password level |
| 4 «Enter» key | |

Proceed as follows:

Open the Settings menu:

- Use the «Up» 2 or «Down» 3 key to navigate to the Settings menu 1 in the menu bar.
- Confirm selection of the Settings menu with the «Enter» 4 key.
 - ✓ Settings menu open

Select/change a setting:

- Navigate to the desired setting using the «Up» or «Down» key.
 - ✓ A frame appears around the line containing the desired setting
- Confirm the selected setting with the «Enter» key.
 - ✓ The frame flashes to indicate ready for input.
- Use the «Up» or «Down» key to set the desired value.
- Confirm and save the setting with the «Enter» key.
 - ✓ The frame stops flashing

Choose another setting:

- Select the next setting using the «Up» or «Down» key.

Exit the Settings menu:

- Press the «Enter» key for ≥ 2 s.
 - ✓ When returning to the menu bar, the Settings menu symbol is highlighted with a black background.

5.2.2 Entering the password

No passwords are set when the machine is delivered. (Password level 0 – lowest access level)
 Should you wish, for example, to amend settings in the Settings menu, first enter the customer password.

Designation	Value
Password level	1
Customer password	4512

Tab. 18 Customer password

The password consists of four digits. Four zeroes are indicated on the display. The following display is the prompt for you to enter the password.

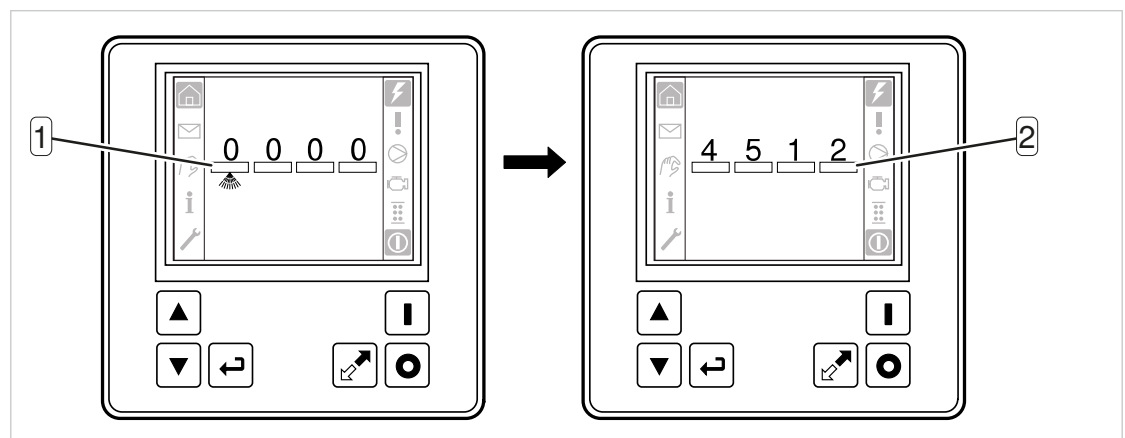

Fig. 23 Entering the customer password

- ① Entry field for customer password
- ② Entry field with customer password

Proceed as follows:

1. Press the «Up» or «Down» key as required until the desired digit is displayed.
2. Press the «Enter» key to confirm the digit entered.
 - ✓ The cursor flashes at the next input position for the password.
3. Enter the 3 remaining digits of the password as per steps 1 and 2 until the whole password has been entered.



Upon confirmation of the final digit, the password is confirmed.
 The activated Settings menu appears on the display.
 Password level 1 is displayed along with the key symbol.

5.2.3 Setting the compressed air discharge pressure

The compressed air discharge pressure can be set whilst the combustion engine is at standstill (controller switched on) or during operation (with the machine running).

- The pressure may only be set to a value lower than the maximum working pressure (rated pressure) for the machine.
- The setting can be adjusted in 0.1 bar / 1 psi increments.
- The setting can be viewed via the indicator on the display.

5.2.3.1 Enabling compressed air adjustment

- The controller is switched on
- Settings menu – page 1 has been selected
- Password level 1 or higher is activated

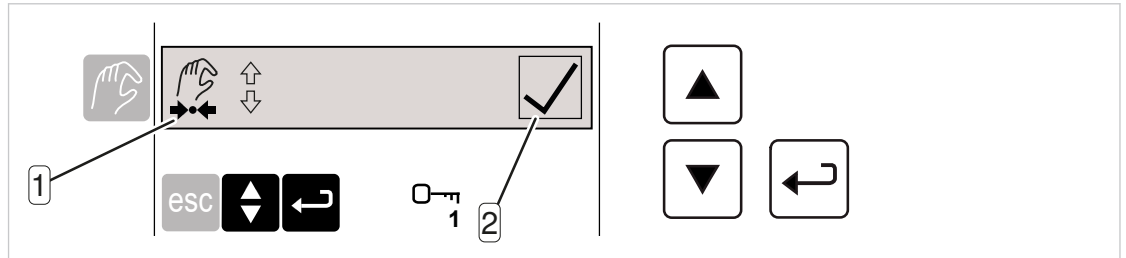
Fig. 24 Enabling compressed air adjustment

- ① Symbol for setting the compressed air discharge pressure
- ② Activating/deactivating

Proceed as follows:

1. Press the «Up» or «Down» key until the line for enabling setting of the setpoint pressure ① is selected.
 - ✓ A frame appears around the relevant line in the Settings menu.
2. Press the «Enter» key to switch to setting mode.
 - ✓ The frame flashes to indicate ready for input. Enabling for setting of the setpoint pressure ② can be switched.

5.2.3.2 Setting the pressure

- The controller is switched on
- Settings menu – page 1 has been selected
- Password level 1 or higher is activated

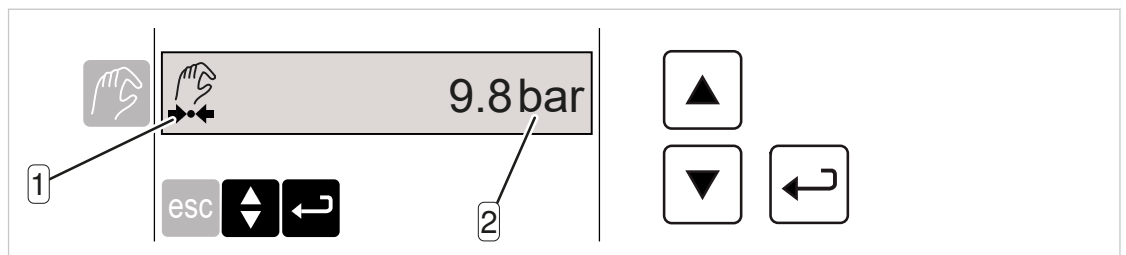
Fig. 25 Setting the compressed air discharge pressure

- ① Setting the compressed air discharge pressure
- ② Set value

Proceed as follows:

1. Press the «Up» or «Down» key until the line for setting the compressed air discharge pressure ① is selected.
 - ✓ A frame appears around the relevant line in the Settings menu.
2. Press the «Enter» key to switch to setting mode.
 - ✓ The frame flashes to indicate ready for input. The value ② can be changed.

5.2.4 Setting the measurement units

The following measurement units can be adjusted on the display:

- Temperature units
- Pressure units



The respective measurement unit need only be adjusted once. All indicators will be adjusted automatically. The settings are saved when the controller is switched off.

5.2.4.1 Setting the pressure units



- The controller is switched on
- Settings menu – page 1 has been selected

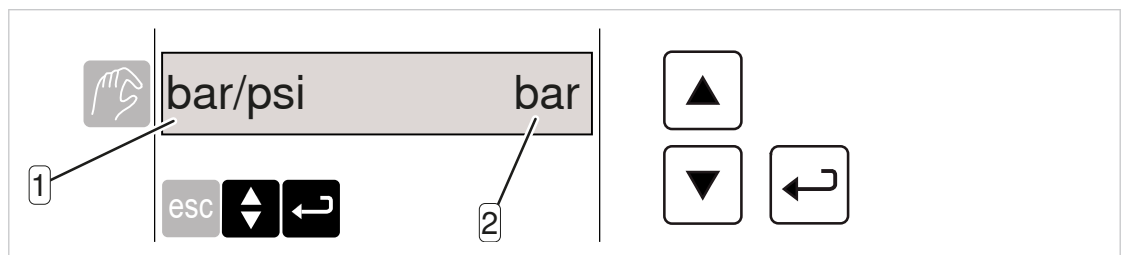

Fig. 26 Setting the pressure units

- ① Pressure unit selection
- ② Set pressure unit

Proceed as follows:

1. Press the «Up» or «Down» key until the line for the pressure units ① is selected.
 - ✓ A frame appears around the relevant line in the Settings menu.
2. Press the «Enter» key to switch to setting mode.
 - ✓ The frame flashes to indicate ready for input. The pressure units ② can be changed.

5.2.4.2 Setting the temperature units



- The controller is switched on
- Settings menu – page 1 has been selected

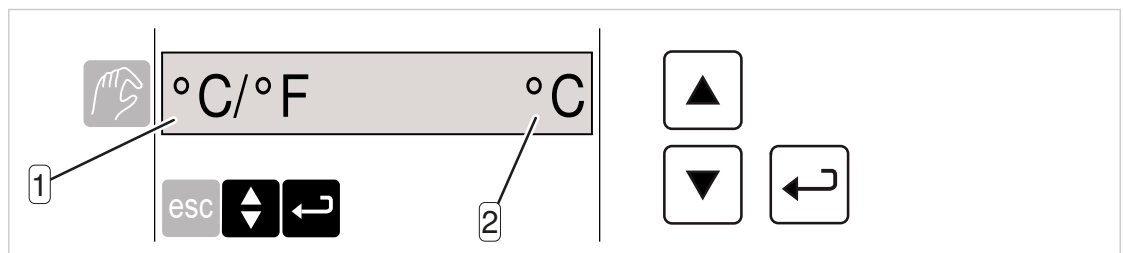

Fig. 27 Setting the temperature units

- ① Temperature unit selection
- ② Set temperature unit

Proceed as follows:

1. Press the «Up» or «Down» key until the line for the temperature units ① is selected.
 - ✓ A frame appears around the relevant line in the Settings menu.
2. Press the «Enter» key.
 - ✓ The frame flashes to indicate ready for input. The temperature units ② can be adjusted.

5.2.5 Setting the display brightness

The setting can be adjusted in 25% increments.



- The controller is switched on
- Settings menu – page 2 has been selected

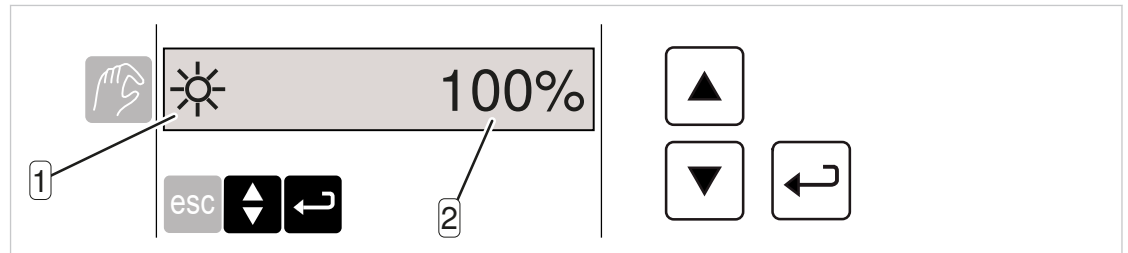

Fig. 28 Adjusting the display brightness

- ① Symbol for the display brightness
- ② Set value

Proceed as follows:

1. Press the «Up» or «Down» key until the line for the display brightness ① is selected.
 - ✓ A frame appears around the relevant line in the Settings menu.
2. Press the «Enter» key to switch to setting mode.
 - ✓ The frame flashes to indicate ready for input. The display brightness ② can be adjusted.

5.2.6 Setting automatic regeneration for the diesel particulate filter

Automatic regeneration of the diesel particulate filter is activated as the default factory setting. Regeneration of the diesel particulate filter can be switched off for the current operating cycle. After the machine has been shut down and restarted, automatic regeneration is activated again.



- The controller is switched on
- Settings menu – page 2 has been selected

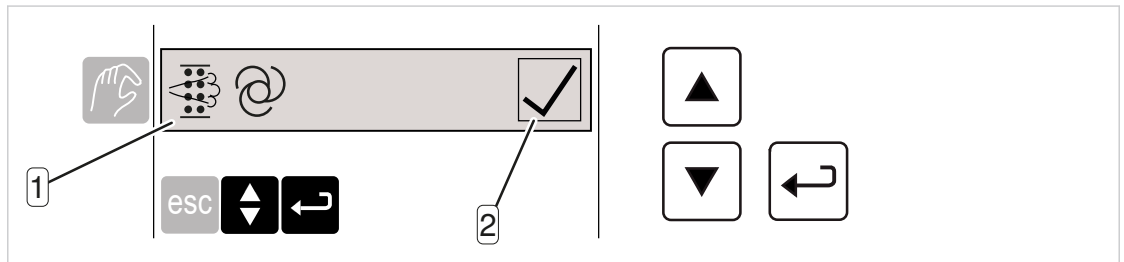

Fig. 29 Setting regeneration mode for the diesel particulate filter

- 1 Diesel particulate filter regeneration
- 2 Activating/deactivating

Proceed as follows:

1. Press the «Up» or «Down» key until the line for regeneration of the diesel particulate filter 1 is selected.
 - ✓ A frame appears around the relevant line in the Settings menu.
2. Press the «Enter» key to switch to setting mode.
 - ✓ The frame flashes to indicate ready for input. Regeneration of the diesel particulate filter 2 can be activated/deactivated.

5.2.7 Switching the engine control unit to continuous operation

The option of switching the engine control unit (ECU) to continuous operation is intended for service purposes.



- The controller is switched on
- Settings menu – page 2 has been selected

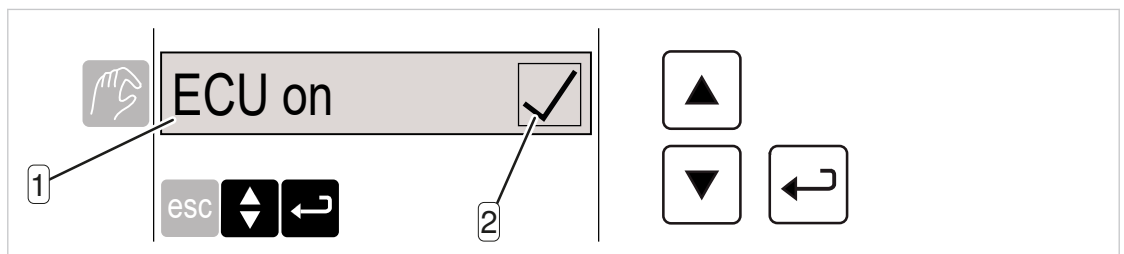

Fig. 30 Activating continuous operation on the engine control unit

- 1 Symbol for activating continuous operation on the engine control unit
- 2 Activating/deactivating

Proceed as follows:

1. Press the «Up» or «Down» key until the line for activating continuous operation on the engine control unit ① is selected
 - ✓ A frame appears around the relevant line in the Settings menu.
2. Press the «Enter» key to switch to setting mode
 - ✓ The frame flashes to indicate ready for input.
Activation of continuous operation on the engine control unit ② can be switched.

5.2.8 Operating the external filling device with separate fuel pump

If the machine's internal fuel tank is to be filled from an external container, a separate fuel pump is required.

You can activate the external filling device via the controller's Settings menu.

The controller assesses the fuel level in the internal fuel tank and switches the separate fuel pump on and off accordingly.



- The controller is switched on
- An external fuel tank is filled and connected
- Settings menu – page 2 has been selected
- Password level 1 or higher is activated

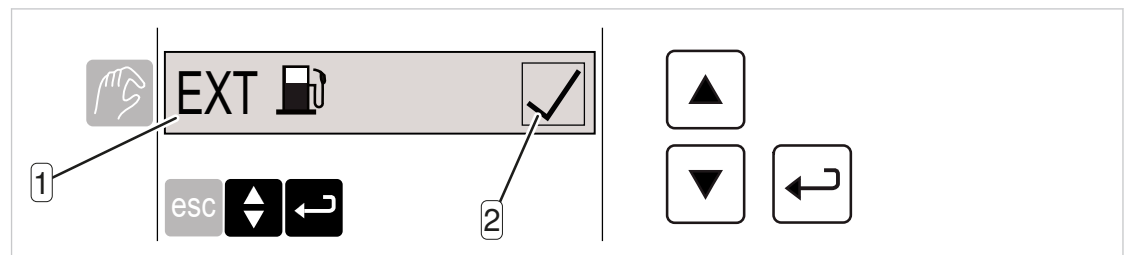

Fig. 31 External filling device setting

- ① Symbol for activating the external filling device
- ② Activating/deactivating

Proceed as follows:

1. Press the «Up» or «Down» key until the line for enabling the external filling device ① is selected
 - ✓ A frame appears around the relevant line in the Settings menu.
2. Press the «Enter» key to switch to setting mode
 - ✓ The frame flashes to indicate ready for input.
Enabling for the external filling device ② can be switched.

5.2.9 Activating the radio remote control

You can activate the radio remote control function via the controller's Settings menu.



- The controller is switched on
- Settings menu – page 8 has been selected
- Password level 1 or higher is activated

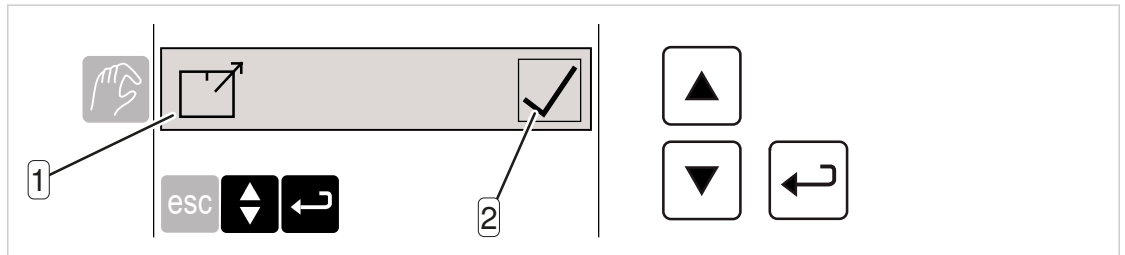

Fig. 32 Activating the radio remote control

- ① Symbol for setting the radio remote control
- ② Activating/deactivating

Proceed as follows:

1. Press the «Up» or «Down» key until the line for activating the radio remote control ① is selected
 - ✓ A frame appears around the relevant line in the Settings menu.
2. Press the «Enter» key to switch to setting mode
 - ✓ The frame flashes to indicate ready for input.
Radio remote control ② can be activated/deactivated.

6 Operation

6.1 Testing the safety functions

The following safety functions can be conducted by an approved expert (e.g. a member of a technical inspection association):

- Testing the safety valve
- Testing the temperature shutdown function

6.1.1 Activating the test mode



- The controller is switched on
- Settings menu – page 2 has been selected
- Password level 1 or higher is activated

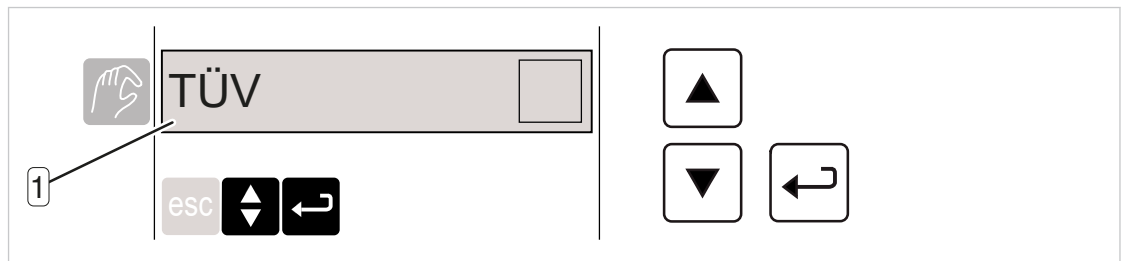

Fig. 33 Selecting the acceptance

1 Test mode

Proceed as follows:

1. Press the «Up» or «Down» key until the line for the test mode 1 is selected.
 - ✓ A frame appears around the relevant line in the Settings menu.
2. Press the «Enter» key to switch to setting mode
 - ✓ The frame flashes to indicate ready for input.
The test mode can be activated/deactivated.
The TÜV menu opens.

6.1.2 Testing the safety valve

The machine increases the pressure until the safety valve is actuated. For the safety valve actuating pressure, see the separate operating manual for the machine, chapter "Safety valve actuating pressure".

WARNING

Danger of hearing damage when safety valve blows off

- ▶ Wear ear protection

CAUTION

Risk of burns from released compressor oil and compressed air

- ▶ Wear protective clothing
- ▶ Wear eye protection
- ▶ Close the machine housing completely



As soon as the safety valve actuating pressure is reached:

- The safety valve is triggered and the pressure reduced.
- The machine shuts down with "Overpressure error" (code 1201).
- The machine displays the maximum pressure ①.

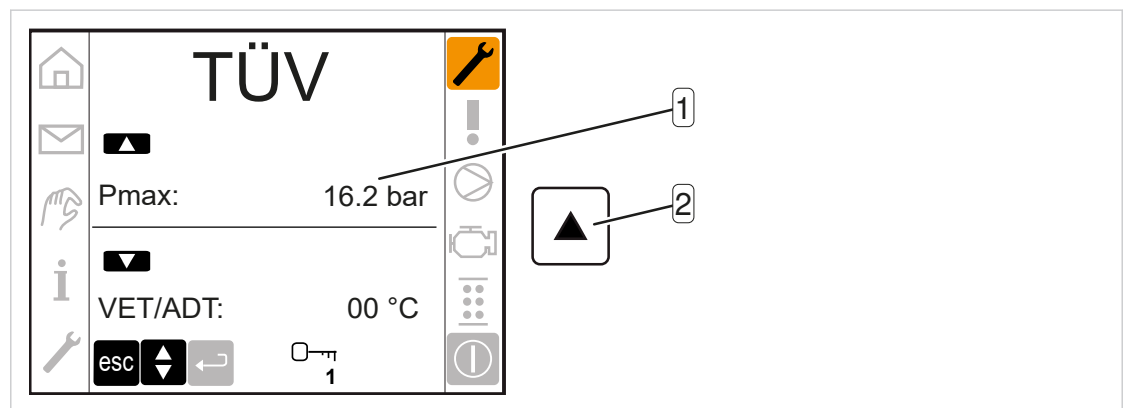

Fig. 34 Testing the safety valve

- ① Maximum pressure reached
- ② «Up» key

Proceed as follows:

1. Press and hold down the «Up» key.
 - ✔ The machine begins to increase the pressure.
2. Release the «Up» key when the maximum pressure is reached.
3. Confirm with the «Enter» key.
 - ✔ When returning to the menu bar, the Settings menu symbol is highlighted with a black background.



In the event that the safety valve does not blow off when maximum pressure is reached:

- Decommission the machine immediately and cease further operation.
- Arrange inspection and/or replacement of the safety valve.

6.1.3 Testing the airend discharge temperature safety shutdown

To test this function, the controller simulates a higher airend discharge temperature. In test mode, a constant temperature value of 50 °C is added to the actual airend discharge temperature in order to cause the machine to shut down prematurely.

The airend discharge temperature increases up to the maximum value.



The controller regulates the safety shutdown as follows:

- Airend discharge temperature 116 °C:
 - The *excessive temperature error* warning is displayed. (Code 3200)
 - The machine switches to the IDLE operating point and is vented.
- Airend discharge temperature 117 °C:
 - The machine is shut down immediately.
 - The *excessive temperature error* fault is displayed. (Code 1200)

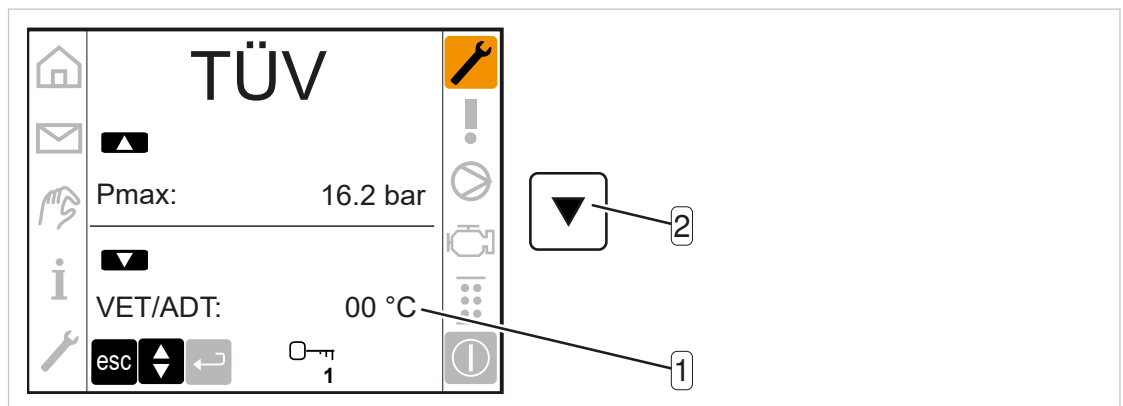

Fig. 35 Selecting the acceptance

- ① Airend discharge temperature
- ② «Down» key

Proceed as follows:

1. Press and hold down the «Down» key ②.
 - ✓ The machine switches to the LOAD operating point and thereby increases the airend discharge temperature.
2. Release the «Down» key when the airend discharge temperature reaches 117 °C.
3. Confirm with the «Enter» key.
 - ✓ When returning to the menu bar, the Settings menu symbol is highlighted with a black background.



In the event that the machine does not shut down when the maximum airend discharge temperature is exceeded:

- Decommission the machine immediately and cease further operation.
- Arrange for the machine to be checked.

6.2 Adjusting the fan

The following settings are possible for the fan:

Setting	Description
MIN	The fan runs at minimum speed.
VAR	The compressor regulates the fan speed itself; the compressor thereby runs at variable speed.
1200 rpm	The fan runs at a speed of 1200 rpm.
MAX	The fan runs at maximum speed.

Tab. 19 Available settings for the fan



- The controller is switched on
- Settings menu – page 5 has been selected
- Password level 1 or higher is activated

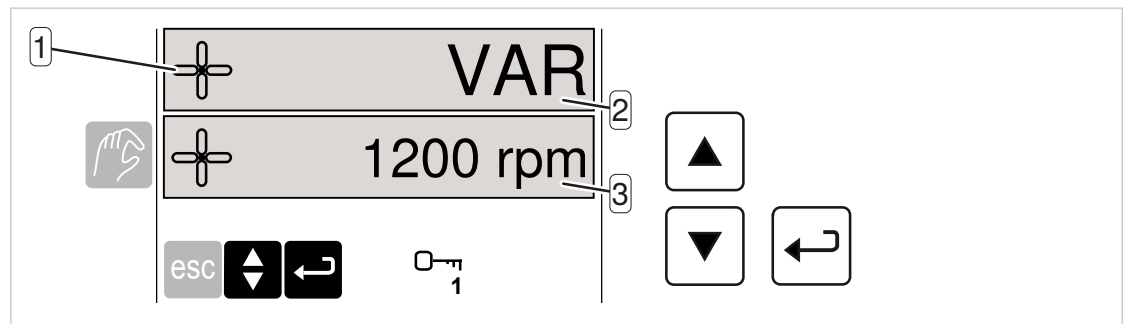

Fig. 36 Adjusting the fan

- ① Symbol for the fan
- ② Set variant
- ③ Fan speed indicator

Proceed as follows:

1. Press the «Up» or «Down» key until the line for the set variant ① is selected.
 - ✓ A frame appears around the relevant line in the Settings menu.
2. Press the «Enter» key to switch to setting mode.
 - ✓ The frame flashes to indicate ready for input. The setting for the speed variant ② can be adjusted. The speed is indicated in line ③.

6.3 Operation with Automatic start/stop

6.3.1 Activating Automatic start/stop



- The controller is switched on
- Settings menu – page 3 has been selected
- Password level 1 or higher is activated

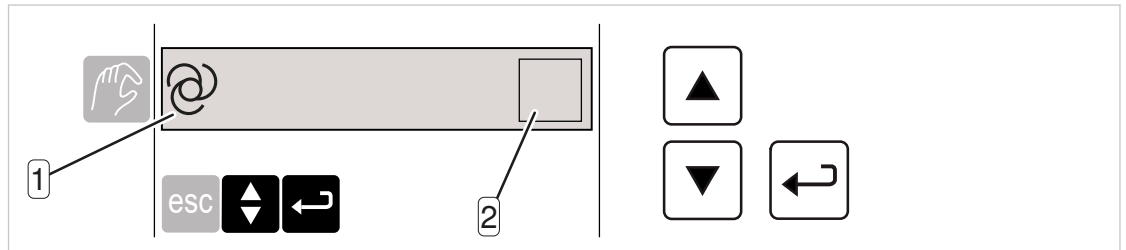

Fig. 37 Activating setting mode for automatic start/stop

- ① *Automatic start* symbol
- ② Automatic start deactivated

Proceed as follows:

1. Press the «Up» or «Down» key until the line with the *Automatic start* symbol ① is selected
 - ✓ A frame appears around the relevant line in the Settings menu.
2. Press the «Enter» key to switch to setting mode
 - ✓ The frame flashes to indicate ready for input.
Automatic start/stop ② can be activated/deactivated.

6.3.2 Setting Automatic start/stop



- The controller is switched on
- Settings menu – page 3 has been selected
- Automatic start/stop is activated
- Password level 1 or higher is activated



Time parameters can be adjusted in 10-Seconds increments.



Fig. 38 Setting Automatic start/stop

- ① Run-on period setting for Automatic start/stop
- ② Cooling-down period setting for Automatic start/stop
- ③ Warm-up period setting for Automatic start/stop

Proceed as follows:

1. Press the «Up» or «Down» key until the line for the desired setting is selected
 - ✓ A frame appears around the relevant line in the Settings menu.
2. Press the «Enter» key to switch to setting mode
 - ✓ The frame flashes to indicate ready for input.
The value can be adjusted.

6.3.3 Ending Automatic start/stop mode

Switching from Automatic start/stop to manual operation is possible both when the machine is at a standstill and when it is running.

Proceed as follows:

- ▶ Press the «ON» or «OFF» key for ≥ 2 s.



SIGMA CONTROL SMART switches the machine from the current automatic start/stop mode to manual operation.

Manual operation applies to the current operating cycle only. The automatic start/stop mode is automatically reselected following machine shutdown and restart.

6.4 Reference run for error acknowledgement

With the Cummins engine, certain pending errors cannot be deleted by means of switching the controller voltage off and back on, despite the error having been resolved.

- Once the cause of the error has been resolved, an unloaded reference run of the combustion engine is required to reset the error.
- In spite of any pending errors, the combustion engine starts and runs in the IDLE operating point.
- Switching over to the LOAD operating point is not possible.
- The duration of the reference run varies and can last up to 60 Seconds.



If the error cannot be automatically acknowledged (deleted) by the reference run, the combustion engine stops after a maximum of 70 Seconds. The error remains pending.

The machine behaviour will depend on the selected operating mode:

Error in “manual” operating mode (normal control):

- The machine controller voltage is switched back on once the error has been resolved and an attempt to acknowledge the error has been made (switching the «Controller «ON»/«OFF»» switch off and back on).
- One of the aforementioned errors persists and is displayed. In spite of this, the green READY indicator flashes.
- Start the machine in spite of the error (IDLE operating point only)
- Wait until the error symbols in the status bar disappear.
- Immediately after the reference run and error acknowledgement, the machine is in normal operating mode and changeover to the LOAD operating point is possible.

Error in Automatic start/stop control mode:

- The machine controller voltage is switched back on once the error has been resolved and an attempt to acknowledge the error has been made (switching the «Controller «ON»/«OFF»» switch off and back on).
- One of the aforementioned errors persists and is displayed. In spite of this, the green READY indicator flashes.
- Start the machine in spite of the error (IDLE operating point only)
- Wait until the error symbols in the status bar disappear.
- Following a successful automatic acknowledgement, the machine stops and is ready for activation of *automatic* mode.

7 Fault recognition and rectification

There are three types of message:

- Fault messages
- Warning messages
- Maintenance messages

The messages applicable to your individual machine depend on the controller factory settings and the equipment specified with the machine.

7.1 Fault message on the controller



A pending fault always results in automatic shutdown of the machine.

The screen displays the symbol for the error source.

It can be composed of one symbol or a combination of multiple symbols.

The controller displays the fault code beneath the symbol.

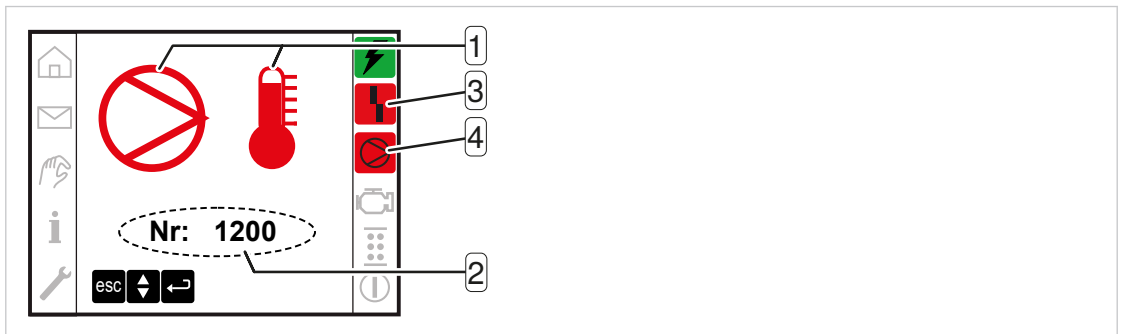

Fig. 39 Example fault message: Airend discharge temperature high

- | | |
|-----------------------------|-------------------------------|
| ① Error localisation symbol | ③ <i>Fault</i> indicator |
| ② Code | ④ <i>Compressor</i> indicator |

7.1.1 Confirming and acknowledging a fault message



The machine has been shut down due to a fault.

The machine cannot be started.



- The fault has been properly resolved
- The controller is switched on

Proceed as follows:

Confirming a fault message:

1. Confirm the fault message with the «Enter» key.
 - ✓ The fault message is extinguished.
 - The fault symbol on the status bar remains active.

Acknowledging a fault message:

2. Switch off the «Controller ON/OFF» switch.

7 Fault recognition and rectification

7.1 Fault message on the controller

3. Switch the «Controller ON/OFF» switch back on.
 - ☑ Restarting the machine acknowledges the fault message. The acknowledged fault message is deleted.



The machine can now be started.

7.1.2 Fault message overview

Engine/motor error fault messages

Code	Message	Action	Where can I get help	
			SW ¹⁾	SP ²⁾
1100	Engine oil pressure (p76) low	Check combustion engine oil level	—	—
		Check combustion engine oil pressure	●	—
		Check oil pressure switch	●	●
1110	Coolant temperature (T70) high	Check coolant level	—	—
		Clean cooler	—	—
		Arrange for water-cooling to be checked	●	●
1111	Coolant level low	Check coolant level	—	—
1121	Charge air temperature (T73) high	Check installation conditions. Allow machine to cool down	—	—
1124	Air flow meter	Arrange for it to be checked	●	●
1130	Fuel level low	Refuel	—	—
1132	Fuel pressure low	Arrange for it to be checked	●	●
1135	Fuel pump	Arrange for it to be checked	●	●
1136	Floor pan liquid level	Drain liquid	—	—
1137	Fuel solenoid	Arrange for it to be checked	●	●
1140	Engine generator not charging	Arrange for it to be checked	●	●
1150	Engine control unit	Arrange for it to be checked	●	●
1151	Engine control unit – SIGMA CONTROL SMART	Arrange for it to be checked	●	●
1160	Rail pressure sensor	Arrange for it to be checked	●	●
1161	Speed sensor	Arrange for it to be checked	●	●
1164	Fuel system	Arrange for it to be checked	●	●
1165	Combustion engine start error	Arrange for it to be checked	●	●
1170	Automatic mode start error	Arrange for it to be checked	●	●

1) Specialist Workshop

2) Service Partner

3) serviced by representative from engine manufacturer

7 Fault recognition and rectification

7.1 Fault message on the controller

Code	Message	Action	Where can I get help	
			SW ¹⁾	SP ²⁾
1180	Exhaust gas after-treatment error	Arrange for diesel particulate filter to be checked	●	●
1186	Exhaust gas after-treatment temperature high	Arrange for diesel particulate filter to be checked	●	●
1192	Diesel particulate filter system	Arrange for diesel particulate filter to be checked	WMH ³⁾	—
1193	NOx monitoring	Arrange for NOx monitoring to be checked	WMH ³⁾	—

1) Specialist Workshop

2) Service Partner

3) serviced by representative from engine manufacturer

Tab. 20 Engine/motor error fault messages, code 1100–1199

Compressor error fault messages

Code	Message	Action	Where can I get help	
			SW ¹⁾	SP ²⁾
1200	Airend discharge temperature	<ul style="list-style-type: none"> ▪ Check installation conditions ▪ Allow machine to cool down 	—	—
		Check compressor oil level	—	—
		Clean cooler	—	—
1201	Pressure in oil separator tank high	Arrange for it to be checked	—	●

1) Specialist Workshop

2) Service Partner

Tab. 21 Compressor error fault messages, code 1200–1299

Controller error fault messages

Code	Message	Action	Where can I get help	
			SW ¹⁾	SP ²⁾
1300	PLC memory error	Arrange for it to be checked	—	●
1302	PLC-HMI communication	Arrange for it to be checked	—	●
1303	PLC temperature high	<ul style="list-style-type: none"> ▪ Check installation conditions ▪ Allow machine to cool down 	—	—
1304	PLC voltage supply	Arrange for it to be checked	—	●
1306	PLC-ECU communication	Arrange for it to be checked	—	●
1310	Watchdog error	Arrange for it to be checked	—	●
1311	I/O module	Arrange for it to be checked	—	●

1) Specialist Workshop

2) Service Partner

Tab. 22 Controller error fault messages, code 1300–1399

General error fault messages

Code	Message	Action	Where can I get help	
			SW ¹⁾	SP ²⁾
1400	EMERGENCY STOP	Unlock	—	—
		Arrange for it to be checked	—	●
1410	Oil separator tank pressure sensor open circuit	Arrange for it to be checked/repaired	—	●
1412	Inlet valve pressure sensor open circuit	Arrange for it to be checked/repaired	—	●
1414	Airend discharge temperature sensor open circuit	Arrange for it to be checked	—	●
1416	Fuel level sensor open circuit	Arrange for it to be checked	—	●
1420	Venting valve open circuit	Arrange for it to be checked/repaired	—	●
1424	Inlet valve control valve open circuit	Arrange for it to be checked	—	●
1450	GSM modem control lock	Arrange for GSM modem to be unlocked	—	●
1475	Network pressure sensor	Arrange for it to be checked/repaired	—	●

1) Specialist Workshop

2) Service Partner

Tab. 23 General error fault messages, code 1400–1499

7.2 Warning message on the controller



A pending warning does not result in automatic shutdown of the machine. The machine continues to run.

The screen displays the symbol for the error source.

It can be composed of one symbol or a combination of multiple symbols.

The controller displays the warning code beneath the symbol.

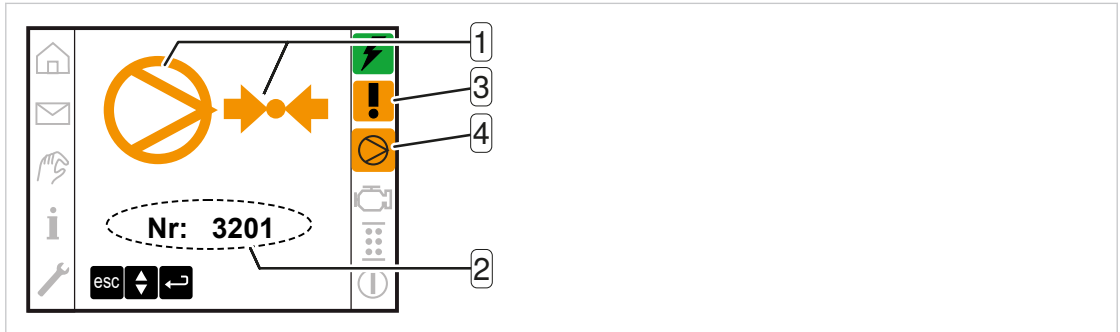

Fig. 40 Warning message example

- | | |
|-----------------------------|-------------------------------|
| ① Error localisation symbol | ③ <i>Warning</i> indicator |
| ② Code | ④ <i>Compressor</i> indicator |



- In the event of an excessive temperature warning, the machine switches automatically to the IDLE operating point to cool down.
- The warning message must be confirmed after resolving the error.

7.2.1 Confirming and acknowledging a warning message



A warning message is displayed before a fault.

The machine does not shut down.



- The machine has been stopped
- The fault hazard has been resolved.
- The controller is switched on

Proceed as follows:

Confirming a warning message:

1. Confirm the warning message with the «Enter» key.
 - ✓ The warning message is extinguished.
 - The warning symbol on the status bar remains active.

Acknowledging the message:

2. Switch off the «Controller ON/OFF» switch.
3. Switch the «Controller ON/OFF» switch back on.
 - ✓ Restarting the machine acknowledges the warning message.
 - The acknowledged warning message is deleted.



The machine can now be started.

7.2.2 Warning message overview
Compressor warning messages

Code	Message	Action	Where can I get help	
			SW ¹⁾	SP ²⁾
3112	Coolant temperature (T70) sensor faulty	Arrange for it to be checked.	●	●
3120	Charge air pressure error	Arrange for charge air pressure sensor to be checked.	●	●
3124	Air flow meter error	Arrange for it to be checked.	●	●
3130	Fuel level low	Refuel.	—	—
3135	Fuel pump	Arrange for it to be checked.	●	●
3136	Fuel filter water level	Empty fuel filter (water separator).	—	—
3150	Engine control unit miscellaneous error	Arrange for it to be checked.	●	●
3154	Combustion engine sensor error	Arrange for it to be checked.	●	●
3155	Combustion engine actuator error	Arrange for it to be checked.	●	●
3164	Fuel system error	Arrange for it to be checked.	●	●
		Clean/replace fuel filter.	—	—
3185	Exhaust gas after-treatment error	Arrange for diesel particulate filter to be checked.	●	●
3188	Exhaust gas after-treatment regeneration required	7.2.3 Initiating parked regeneration	—	—

1) Specialist Workshop

2) Service Partner

Tab. 24 Compressor warning messages, code 3100–3199

Compressor warning messages

Code	Message	Action	Where can I get help	
			SW ¹⁾	SP ²⁾
3200	Airend discharge temperature high	<ul style="list-style-type: none"> ▪ Check installation conditions. ▪ Allow machine to cool down. 	—	—
		Check compressor oil level.	—	—
		Clean cooler.	—	—
3201	Pressure in oil separator tank high	Arrange for it to be checked.	—	●

1) Specialist Workshop

2) Service Partner

Tab. 25 Compressor warning messages, code 3200–3299

Controller warning messages

Code	Message	Action
3303	PLC temperature high	<ul style="list-style-type: none"> ▪ Check installation conditions. ▪ Allow machine to cool down.
3313	HMI temperature high	<ul style="list-style-type: none"> ▪ Check installation conditions. ▪ Allow machine to cool down.

Tab. 26 Controller warning messages, code 3300–3399

7.2.3 Initiating parked regeneration

If sufficiently high exhaust temperatures are maintained whilst the machine is operating, the diesel particulate filter will continuously regenerate itself (passive regeneration). Parked (or stationary) regeneration must be activated when the machine is operated for short periods only, since the exhaust gases do not become hot enough to regenerate the diesel particulate filter.



During “parked regeneration”:

- The machine cannot be operated.
- Regeneration cannot be interrupted once initiated.

“Parked regeneration required” warning message:

The controller displays the message “Parked regeneration required”.

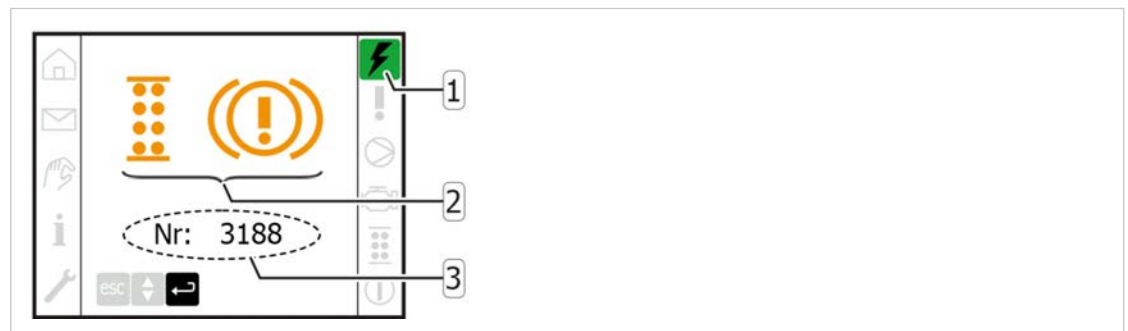

Fig. 41 Warning: “Parked regeneration required”

- ① Controller voltage ON indicator
- ② “Parked regeneration required” symbol (orange)
- ③ Code

Starting parked regeneration:

Fig. 42 "Parked regeneration in progress" indicator

- | | |
|---|--|
| ① Temperature at diesel particulate filter outlet | ⑤ <i>Warning</i> indicator |
| ② Current soot load of diesel particulate filter | ⑥ Combustion engine indicator (orange) |
| ③ "Parked regeneration running" symbol (orange) | ⑦ Diesel particulate filter indicator (orange) |
| ④ "Controller voltage ON" indicator (green) | |

Proceed as follows:

- ▶ Press the «Enter» key for a minimum of 2 seconds.
 - ☑ Parked regeneration starts

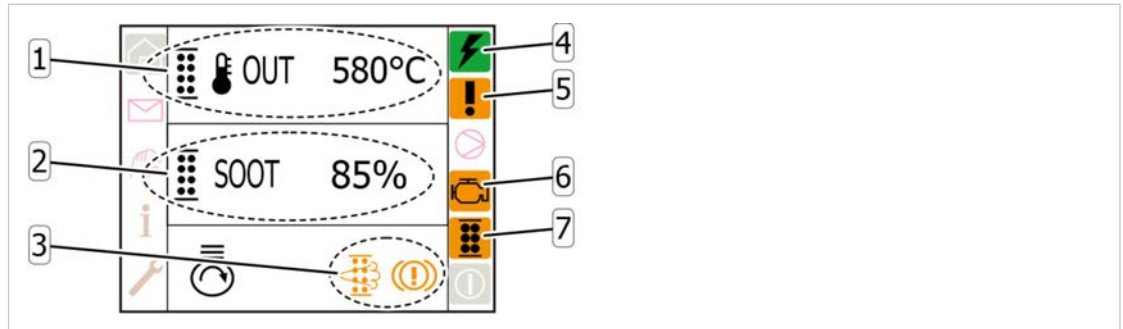

The following operating indicators appear on the display:

- "Parked regeneration" operating state ③.
- Icons ⑤, ⑥ and ⑦ flash orange in the status bar
- The soot load ② [%] drops.
- The exhaust temperature at the outlet for the diesel particulate filter ① [%] rises.



Following completion of the "Parked regeneration" procedure, the machine runs in the IDLE operating point and can be operated again.

7.3 Maintenance message on the controller

The screen displays selected maintenance cycles for the machine. Display commences 25 hours before expiry of the current maintenance cycle.

In the following example, the screen displays the symbol for the pending maintenance. It can be composed of one symbol or a combination of multiple symbols.

The operating hours until the maintenance is due and the message code for the maintenance task are displayed beneath the symbols.

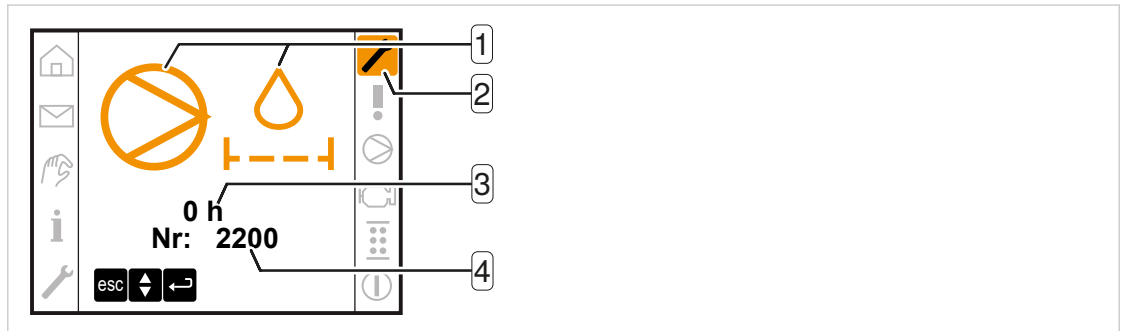

Fig. 43 Maintenance message example: Replace compressor oil filter

- | | |
|-----------------------------|-------------------------|
| ① Error localisation symbol | ③ Code indicator |
| ② Operating hours indicator | ④ Maintenance indicator |

7.3.1 Resetting the maintenance timer

Each maintenance timer must be reset individually.



The maintenance timer can only be reset by entering a password of level 1 or higher.



- Maintenance has been performed
- The controller is switched on

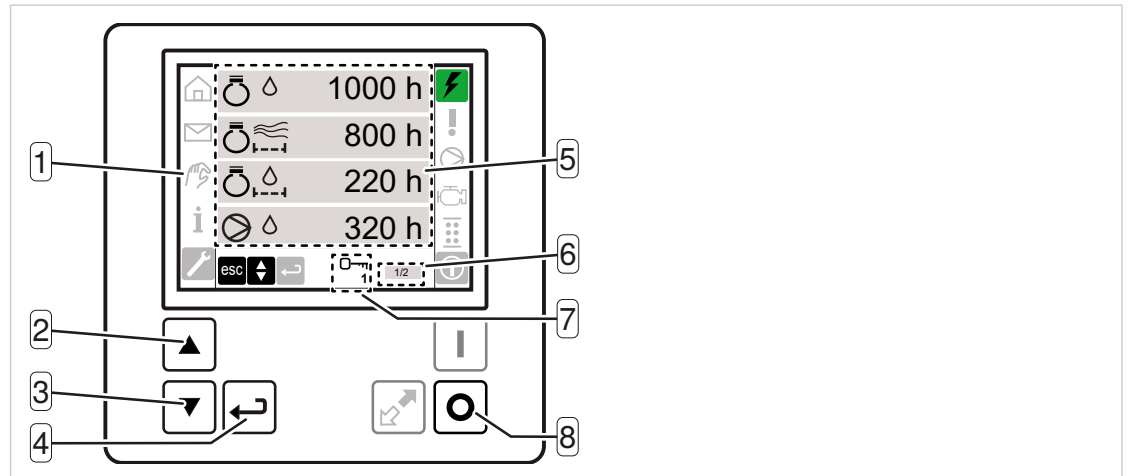

Fig. 44 Selecting the maintenance timer

- | | |
|---------------------------|------------------------------------|
| ① Maintenance menu symbol | ⑤ Different maintenance indicators |
| ② «Up» key | ⑥ Menu page (page 1 of 2) |
| ③ «Down» key | ⑦ Password level 1 |
| ④ «Enter» key | ⑧ «STOP» key |

Proceed as follows:

Select the maintenance timer in the menu structure:

1. Select the maintenance menu ①.
2. Use the «Up» ② or «Down» ③ key to navigate to the desired maintenance indicator ⑤.
 - ✓ A frame will appear around the maintenance indicator.
3. Hold down the «STOP» key ⑧ and simultaneously press the «Enter» key ④ briefly.
 - ✓ The password entry menu opens

Reset the maintenance timer:

4. Enter the password
 - ✓ The display returns to the selected maintenance timer.
5. Hold down the «STOP» key and simultaneously press the «Enter» key briefly to confirm.
 - ✓ The remaining time to the next maintenance is displayed in hours.
6. Release the «STOP» key.



The entered password will remain active for 3 Minutes after the last time the keypad was touched. The next completed maintenance can be confirmed immediately and the respective maintenance timer reset.

Exit the maintenance indicator menu:

7. Press the «Enter» key for ≥ 2 s.
 - ✓ The Settings menu is closed and the main menu displayed.

7.3.2 Maintenance message overview

Combustion engine maintenance messages

Code	Message	Action
2100	Maintenance: Replace combustion engine oil filter	Change combustion engine oil filter
2101	Maintenance: Clean/replace combustion engine air filter	Clean/change air filter
2102	Maintenance: Change engine oil	Change engine oil

Tab. 27 Combustion engine maintenance messages, code 2100–2199

Compressor maintenance messages

Code	Message	Action
2200	Compressor oil filter	Change compressor oil filter
2201	Compressor air filter	Clean or replace air filter.
2202	Compressor cooling oil	Change cooling oil.

Tab. 28 Compressor maintenance messages, code 2200–2299

8 Annexe

8.1 Starting / shutting down the operating sequence

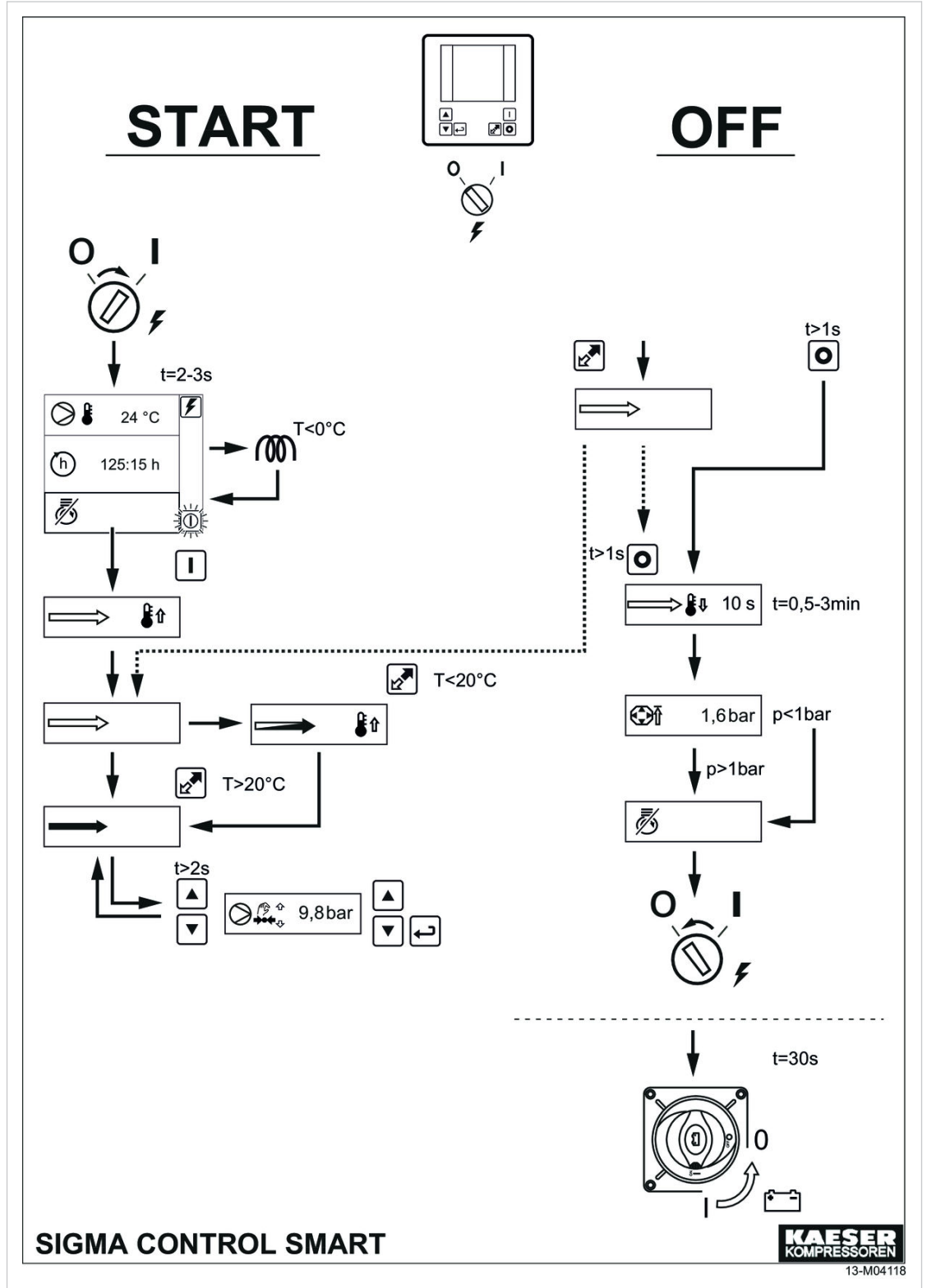

Fig. 45 Starting / shutting down the operating sequence

8.2 Starting / shutting down the operating sequence (Automatic start/stop)

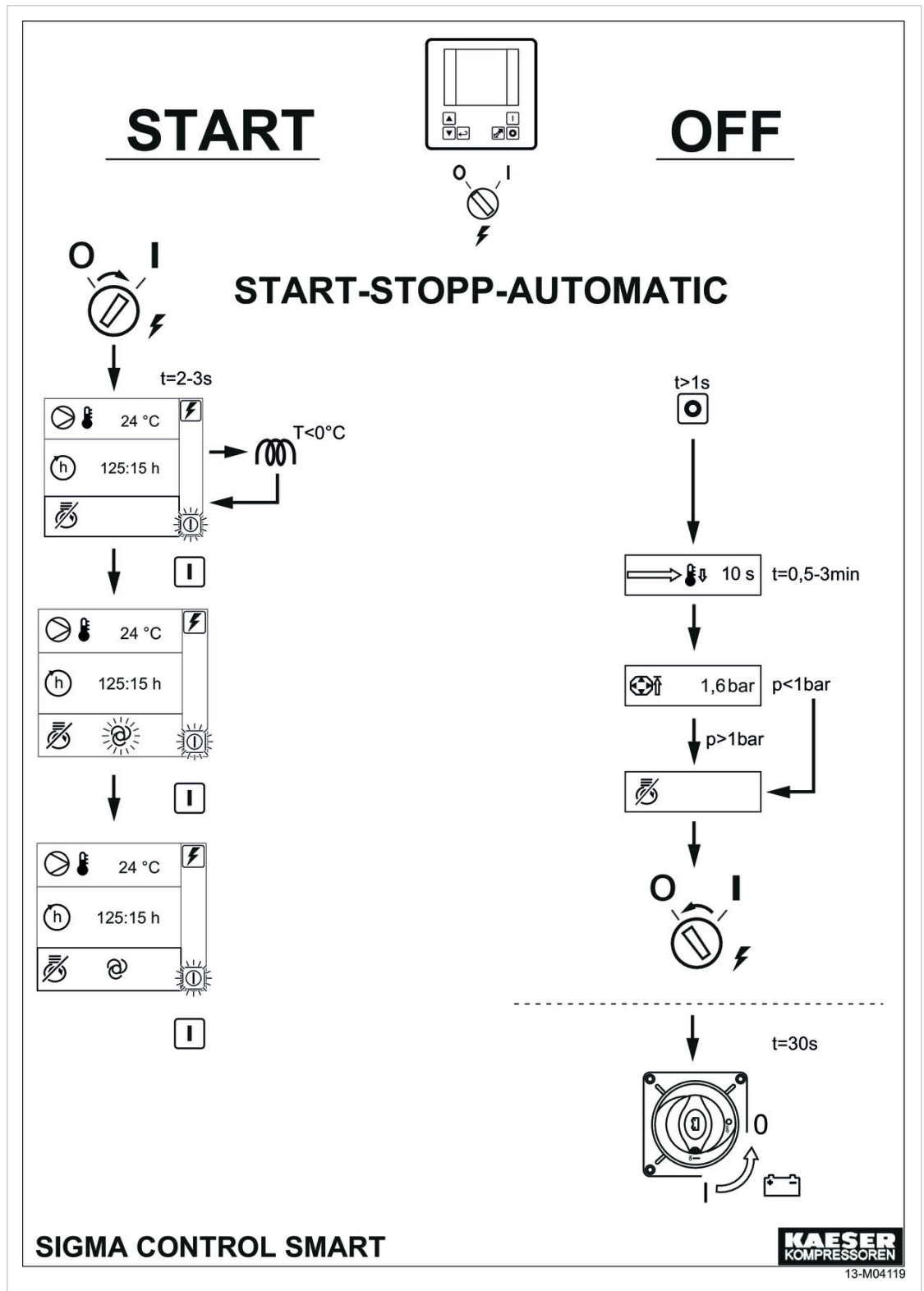

Fig. 46 Starting / shutting down the operating sequence (Automatic start/stop)

8.3 Menu display

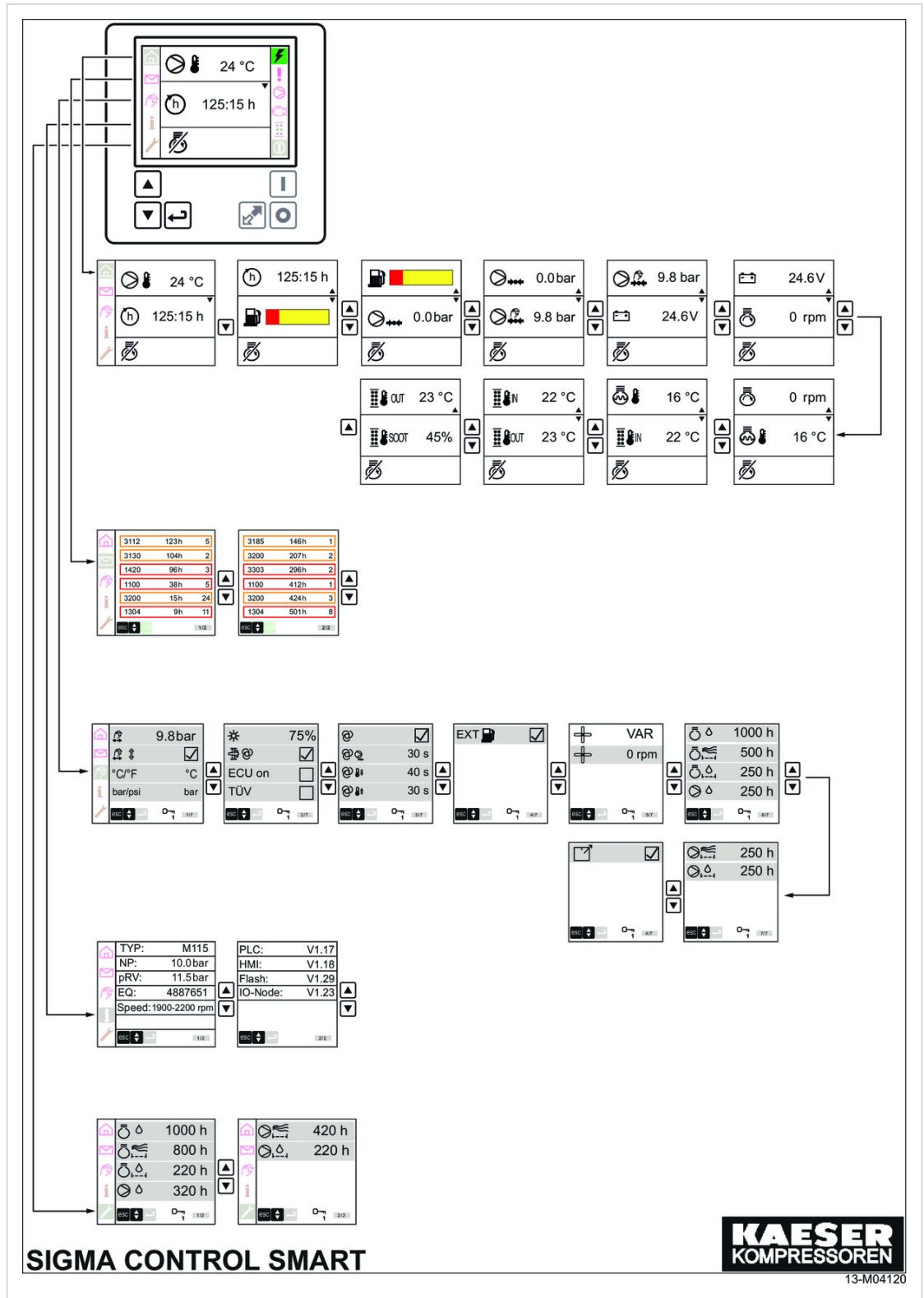

Fig. 47 Menu display

A

- Activating the radio remote control [39](#)
- Adjusting the display brightness [37](#)
- Automatic start/stop [45](#)
 - Activating [45](#)
 - Ending [46](#)
 - Setting [45](#)
- Automatic START/STOP [31](#)

C

- Controller settings [33](#)
- Controller voltage [32](#)
- Copyright [11](#)

D

- Diesel particulate filter
 - Enabling regeneration [38](#)
 - Initiating regeneration [54](#)
 - Parked regeneration [54](#)
 - Regeneration level [30](#)
- Display [16](#)
- Display elements [6](#), [14](#)
- Document [10](#)

E

- Enabling compressed air adjustment [35](#)
- Error acknowledgement [47](#)
- Error memory [20](#)
- External filling device [39](#)

F

- Fault messages [48](#)
 - Confirming
 - Acknowledging [48](#)
 - Overview [49](#)
- Functions [9](#)

M

- Main menu [18](#)
- Maintenance indicator [27](#)
- Maintenance messages [56](#)
 - Overview [57](#)
 - Resetting the timer [56](#)
- Material damage [10](#)
- Menu
 - Error memory [20](#)
 - Main menu [18](#)
 - Maintenance indicator [27](#)
 - Settings menu [21](#)
 - System information [25](#)
- Menu structure [8](#)

O

- Operating elements [5](#), [13](#)
- Operating sequence [28](#)

P

- Password entry [34](#)
- Pictogram [11](#)

Q

- Quick reference guide [5](#)

R

- Reference run [47](#)
- Regeneration level [30](#)

S

- Safety functions
 - Activating the test mode [41](#)
 - Airend discharge temperature [43](#)
 - Arranging testing [41](#)
 - Testing the safety valve [42](#)
- Setting the compressed air discharge pressure [34](#)
- Setting the measurement units [36](#)
- Setting the pressure [35](#)
- Setting the pressure units [36](#)
- Setting the temperature units [36](#)
- Settings [33](#)
 - Changing [33](#)
 - Compressed air discharge pressure [34](#)
 - Display brightness [37](#)
 - Fan [44](#)
 - Measurement units [36](#)
 - Pressure [35](#)
 - Pressure units [36](#)
 - Temperature units [36](#)
- Settings menu [21](#)
- Switch on the engine control unit [38](#)
- Symbol [11](#)
- System information [25](#)

W

- Warning messages [52](#)
 - Acknowledging [52](#)
 - Confirming [52](#)
 - Overview [53](#)
- Warning notice [10](#)